

Digital amplifier- and controller electronics MD2

- Robust construction for mobile applications
- For 4 or 8 proportional- or switching solenoids
- Plug-in connection suitable for mobile applications
- Protection class IP67
- Adjustable via PC
- CANopen®-Connection
- Available as amplifier or controller

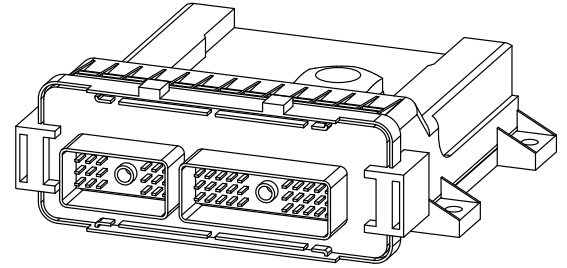

DESCRIPTION

Digital amplifier electronics, with four or eight solenoid outputs. They are characterised by a robust and compact construction. The extensive supply voltage range enables the driving of 12VDC- and 24VDC- devices. The parameterisation takes place through the menu-controlled parameterisation- and diagnostics software «PASO» of Wandfluh (USB-interface). The electronics are available as an amplifier - and as a controller function with optional CAN-interface (according to CANopen® DSP-408).

FUNCTION

The electronics have four, resp., eight pulse width modulated current outputs with superimposed dither signal. The solenoid outputs can also be parameterised for black/white solenoids. The two, resp. four analogue- and digital inputs as well as the two digital outputs are individually programmable. With the device, control- and closed-circuit control tasks can very easily be solved. The CAN-connection enables the reading-in of command value- and feedback value signals as well as the parameterisation directly through the field-bus.

APPLICATION

Screwed on to a metallic surface, the amplifier electronics are used primarily in the mobile field because of their compact construction, explosion protection class IP67, extensive operating temperature range and the selected plug-in connection. Customer-specific requirements can easily be implemented.

CONTENT

GENERAL SPECIFICATIONS..... 1

ELECTRICAL SPECIFICATIONS..... 2

BLOCK DIAGRAM..... 3

DIMENSIONS/ASSEMBLY/
ACCESSORIES..... 4

CONNECTOR WIRING DIAGRAM 5

START-UP 5

ADDITIONAL INFORMATION 5

DESCRIPTION AMPLIFIER 6-8

DESCRIPTION CONTROLLER 9-10

TYPE CODE

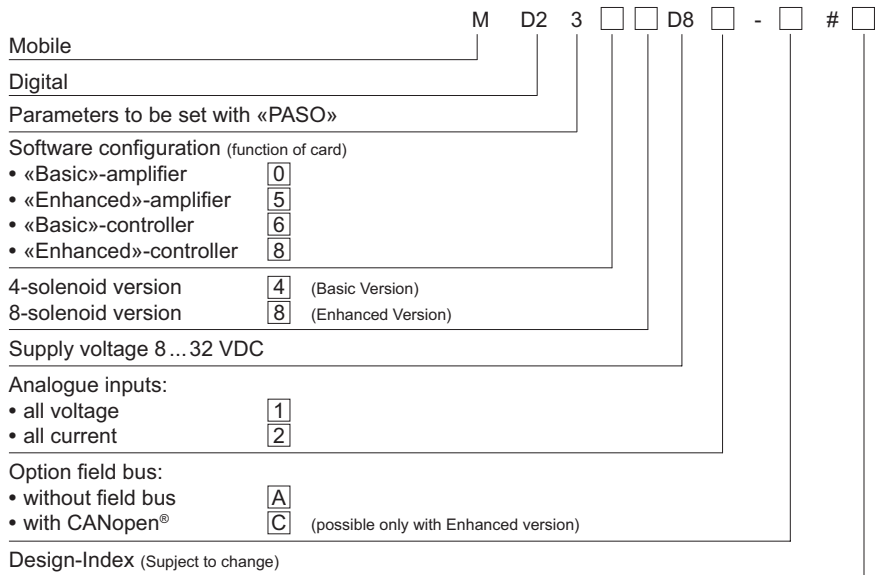

GENERAL SPECIFICATIONS

Execution	Housing made of plastic
Dimensions	153x57x147 (see dimensions)
Installations	On metallic surface, screwed on
Weight	0,50 kg
Device receptacle (male)	Type SHS, 30/48-poles (Manufacturer CINCH, www.cinch.com)
Mating connector	Plug (female) type SHS, 30-poles (not incl. in delivery)
Mating connector	Plug (female) type SHS, 18-poles (for MD2 «Enhanced» only, not incl. in delivery)
Working temperature	-40...+85°C
Environmental compatibility	The material limit values from the RoHS-directive (2002/95/EC) and the ELV «end-of life vehicles directive» (2000/53/EC) are complied with.

ELECTRICAL SPECIFICATIONS

Protection class	IP67 acc. to DIN/EN 60 529	Dither	Frequency adjustable 20...500 Hz
Supply voltage	8...32 VDC (for logic part) 8...32 VDC (for solenoid outputs)		Factory-preset 100 Hz
Ripple on supply vol.	<10%		Amplitude adjustable 0...400 mA
Fuse	slow-blow	Temperature drift	Factory-preset 100 mA
Current consumption:		Digital inputs	<1 % at $\Delta T = 40^\circ C$
• No-load current	approx. 55 mA		Switching threshold high 6...32 VDC
• Maximum current consumption	no-load current + 2 A per solenoid		Switching threshold low 0...1 VDC
Command value signal:	MD23..D81-A: 0...+5 V/0...+10 V/-10...+10 V	Digital outputs	Utilisable as frequency input (frequencies 0...5 kHz) and as PWM-input
	MD23..D82-A: 4...20 mA/0...+20 mA		(automatic frequency identification)
	Basic: Analogue inputs 1 and 2: 10-Bit resolution	Ramps adjustable	High-Side-Switch
	Enhanced: Analogue inputs 1 to 4: 16 bit resolution	Serial interface	Maximum load 500 mA
Input resistance	Voltage input > 18 k Ω	LED	per output
Stabilised output voltage	Load for current input = 250 Ω 5 VDC max. load 50 mA	Green:	0...500 s
Solenoid current:			USB (receptacle type B) to set parameters with «PASO»
• Minimal current I_{min}	Adjustable 0...950 mA Factory-preset 150 mA	Red:	- is lit, when the MD2 - electronics are ready for operation.
• Maximal current I_{max}	Adjustable: I_{min} ...2 A Factory-preset 700 mA		- blinks twice, if the supply voltage is too low for the solenoid outputs.
• Accumulated current limitation	10 A The number of solenoids simultaneously supplied with current and their maximum current are dependent on the ambient temperature. Further information can be found in the ope- rating instructions.	EMV	- is lit, when an error has occurred. The cause for the error can be in- dentified by means of the «PASO»- software.
CANopen® interface (optional)	Two-wire line acc. to ISO 11898 differential signal transmission		EN 61 000-6-2
Bustopology	Line		EN 61 000-6-4
Voltage separation	CANopen® to MD2 500 VDC		ISO 7637-2 and RL 2004/104/EC
			IEC 60 068-2-6
			IEC 60 068-2-27
			IEC 60 068-2-29

BLOCK DIAGRAM

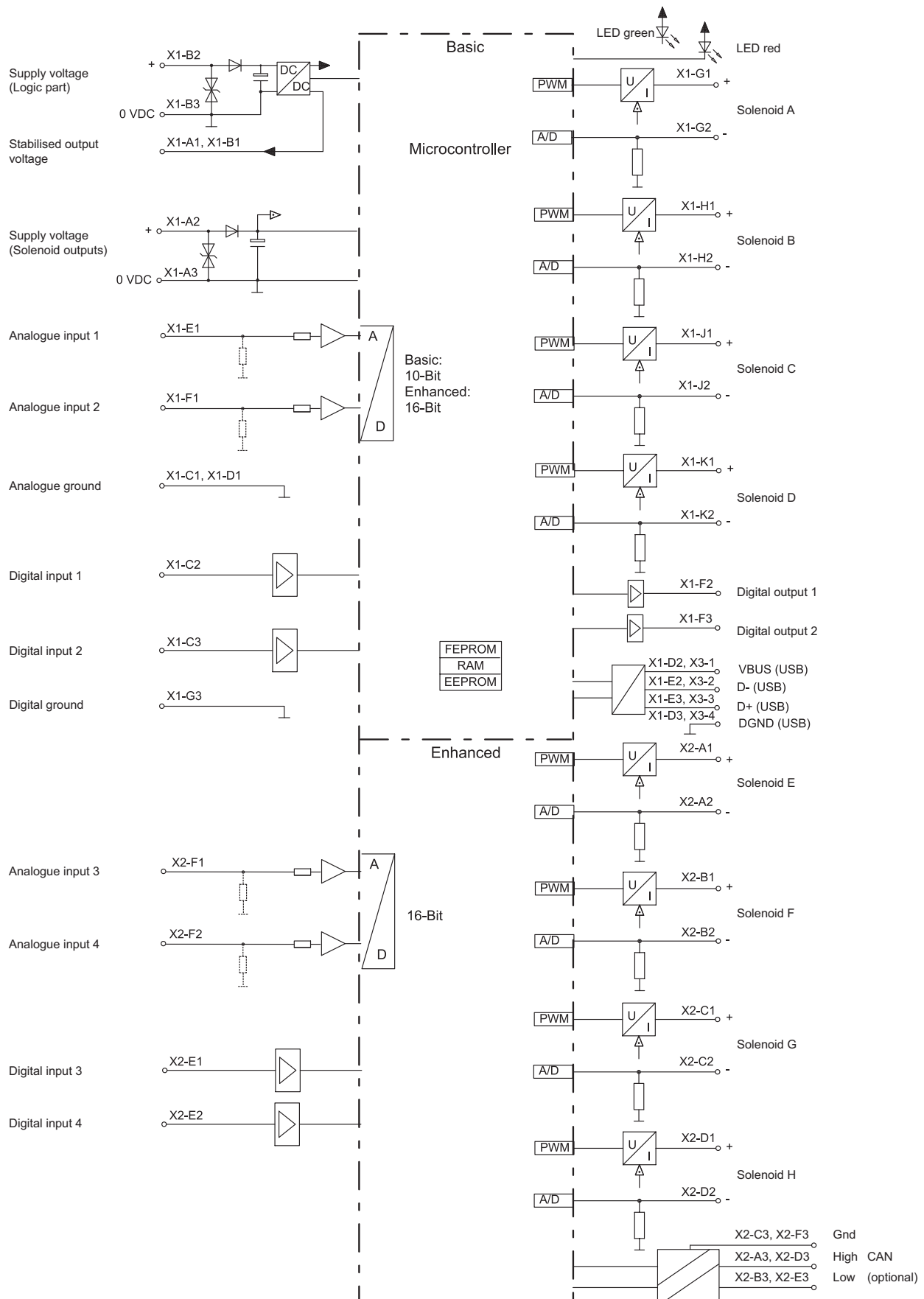

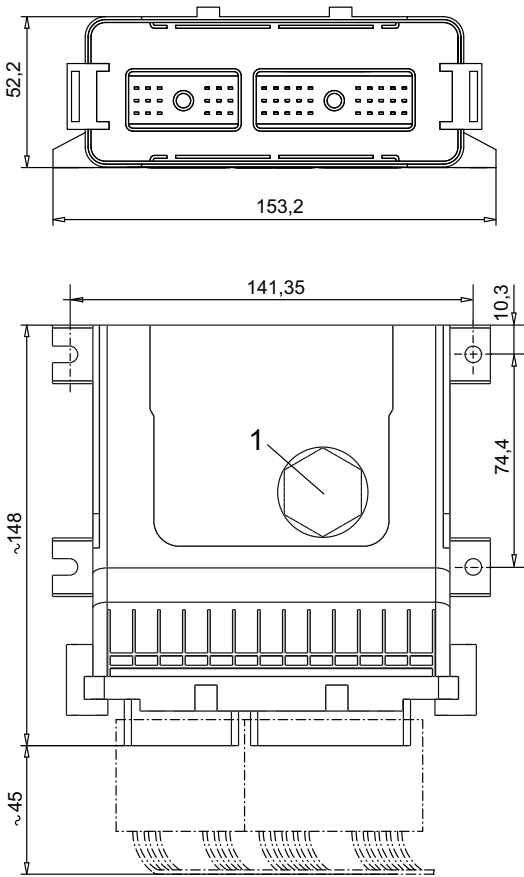
DIMENSIONS

ACCESSORIES

- Parameterisation software Refer to commissioning
- Connection-Set for MD2 «Basic» Wandfluh No 727.9900
 - 1 pce mating connector 30-poles
 - 50 pce crimp terminals
 - 30 pce cavity filler plugs
- Connection-Set for MD2 «Enhanced» Wandfluh No 727.9901
 - 1 pce mating connector 30-poles
 - 1 pce mating connector 18-poles
 - 80 pce crimp terminals
 - 50 pce cavity filler plugs
- Mating connector Plug (female) type SHS 30-poles Cinch No 581 01 30 029
- Mating connector Plug (female) type SHS 18-poles Cinch No 581 01 18 023
- Crimp terminal 0,8–1,0 mm² Cinch No 425 00 00 873
- Cavity filler plug Cinch No 581 00 00 011
- Tool (to open mating connector) Cinch No 599 11 11 628 Wandfluh No 983.0950
- Tool (Hand crimp tool for crimp terminals) Cinch No 599 11 11 616
- Tool (Removal tool for crimp terminals) Cinch No 581 01 18 920

1 Transparent screw-on cap for the access to the USB - interface. The green and the red LEDs are visible without having to remove the screw-on cap.

ASSEMBLY

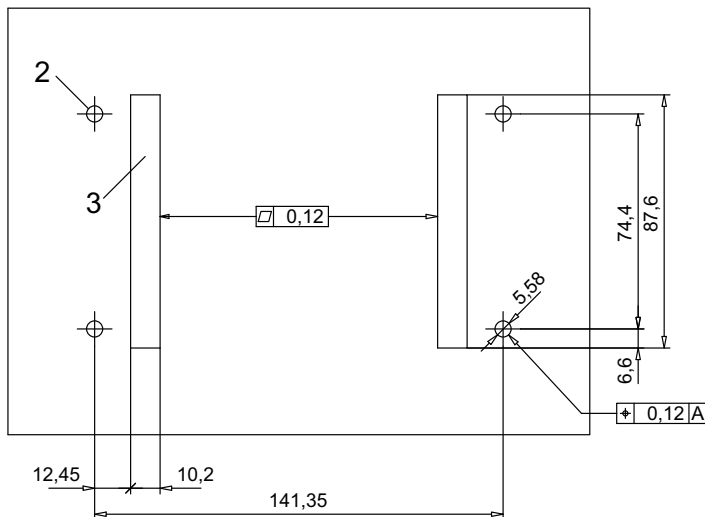
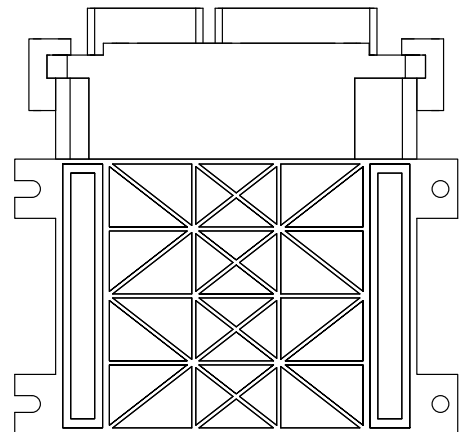
For conducting the heat away, the MD2-electronics have to be installed on a metallic surface.

Mounting surface

View from below

2 Installation bores

3 Contact surface for the cooling body

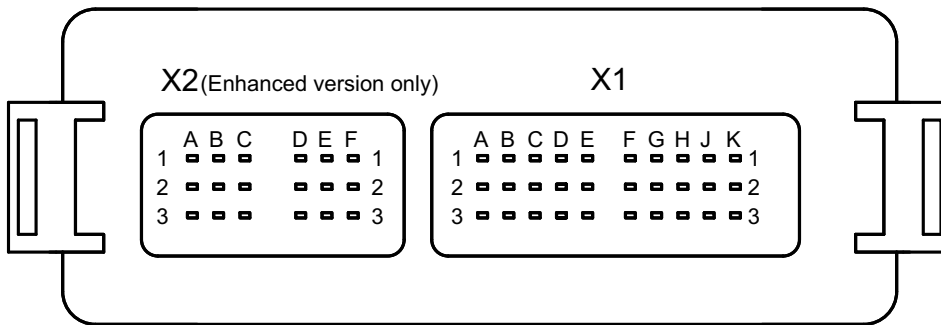
CONNECTOR WIRING DIAGRAM / PIN ASSIGNMENT

DEVICE PLUG (X2; ONLY FOR ENHANCED VERSION)

A1 = Output solenoid E +
 A2 = Output solenoid E -
 A3 = CAN High
 B1 = Output solenoid F +
 B2 = Output solenoid F -
 B3 = CAN Low
 C1 = Output solenoid G +
 C2 = Output solenoid G -
 C3 = CAN Gnd
 D1 = Output solenoid H +
 D2 = Output solenoid H -
 D3 = CAN High
 E1 = Digital input 3
 E2 = Digital input 4
 E3 = CAN Low
 F1 = Analogue input 3
 F2 = Analogue input 4
 F3 = CAN Gnd

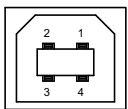
USB-interface (X3, underneath the screw cover)

1 = VBUS
 2 = D -
 3 = D +
 4 = GND

Socket USB type B

Remark!

The parameterisation cable is not part of the scope of supply (commercially available USB-cable, plug type A to plug type B)

START-UP

Information regarding installation and commissioning are contained in the information leaflet supplied with the amplifier module and in the operating instructions.

Additional information can be found on our website:
«www.wandfluh.com»

Free-of-charge download:

- «PASO-MD2» Parameterisation software
- Operating instructions (*.pdf)

DEVICE PLUG (X1)

A1 = Stabilised output voltage
 A2 = Supply voltage + (Solenoid outputs)
 A3 = Supply voltage 0 VDC (Solenoid outputs)
 B1 = Stabilised output voltage
 B2 = Supply voltage + (Logic part)
 B3 = Supply voltage 0 VDC (Logic part)
 C1 = Analogue ground
 C2 = Digital input 1
 C3 = Digital input 2
 D1 = Analogue ground
 D2 = VBUS (USB)
 D3 = GND (USB)
 E1 = Analogue input 1
 E2 = D- (USB)
 E3 = D+ (USB)
 F1 = Analogue input 2
 F2 = Digital output 1
 F3 = Digital output 2
 G1 = Output solenoid A +
 G2 = Output solenoid A -
 G3 = Digital ground
 H1 = Output solenoid B +
 H2 = Output solenoid B -
 H3 = Reserved
 J1 = Output solenoid C +
 J2 = Output solenoid C -
 J3 = Reserved
 K1 = Output solenoid D +
 K2 = Output solenoid D -
 K3 = Reserved

ADDITIONAL INFORMATION

Wandfluh electronics general
 Accessories

Proportional directional valves
 Proportional pressure valves
 Proportional flow control valves

Wandfluh-Dokumentation
 register 1.13
 register 1.13

register 1.10
 register 2.3
 register 2.6

Description of the «MD2»-amplifier electronics

DESIGN

The mobile electronics can be parameterised by means of the parameterisation software «PASO MD2» through the USB-interface. In addition, the parameterisation software makes a data analysis possible. The software «PASO MD2» is supported by Windows 2000, Windows XP and Windows Vista.

DESCRIPTION OF FUNCTION

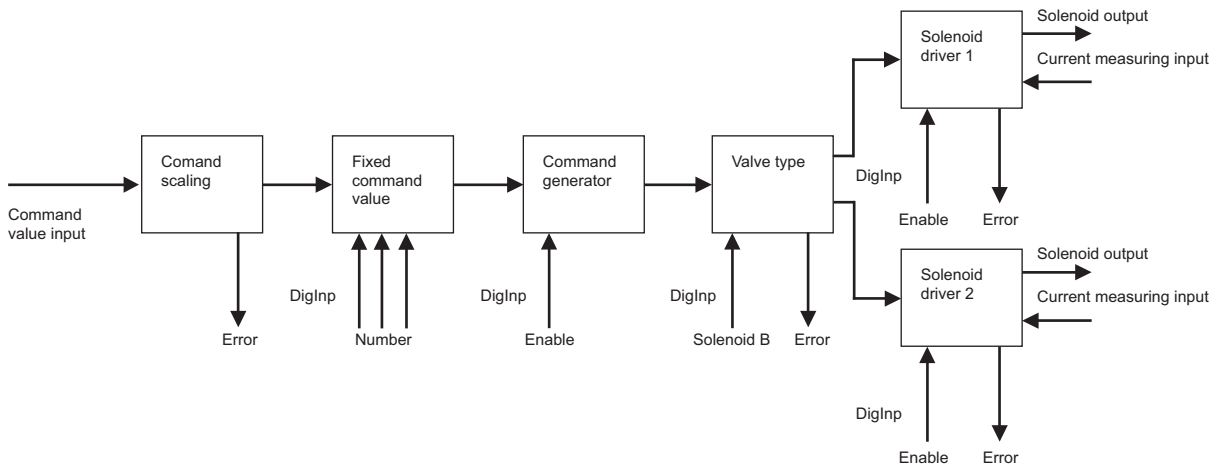

MD2 AMPLIFIER

Command value scaling

The command value can be applied as a voltage -, current -, digital -, frequency - or PWM-signal. For each command value the input utilised can be selected. The scaling takes place through the parameters «Interface» and «Reference». Furthermore each command value can be monitored for cable break (excepting the voltage - and digital signal). For each command value a dead band can be set.

Fixed command values

There are 7 fixed command values available, which can be selected through 3 digital inputs.

Command value generator

Per solenoid output, two linear ramps separately settable for Up and Down are available.

Valve type

Here the operating mode is set, when in open-loop controller mode. In addition it can be selected, whether proportional - or switching solenoids are to be driven.

Operating mode command value unipolar (1-solenoid)

The solenoid is driven in dependence of a unipolar command value signal (voltage, current, frequency or PWM) (e.g., 0...10V correspond to 0...100 % command value, 0...100 % command value correspond to I_{min}...I_{max} solenoid driver 1).

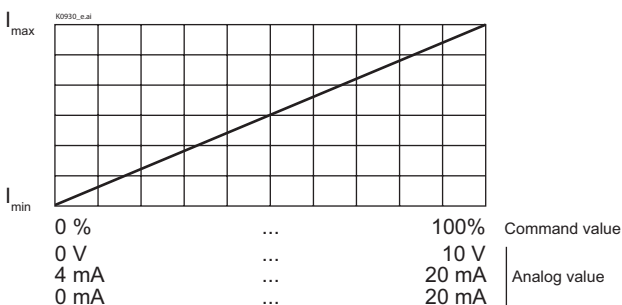

Operating mode command value unipolar (2-solenoids)

Depending on the signal level (voltage, current, frequency or PWM), one of the two solenoids is driven in dependence of a unipolar command value signal. The switching point between the two solenoids, as standard, is at the centre of the values range of the command value signal (e.g., 0...10V correspond to -100...+100 % command value, -100...0 % command value correspond to I_{min}...I_{max} solenoid driver 2, 0...+100 % command value correspond to I_{min}...I_{max} solenoid driver 1).

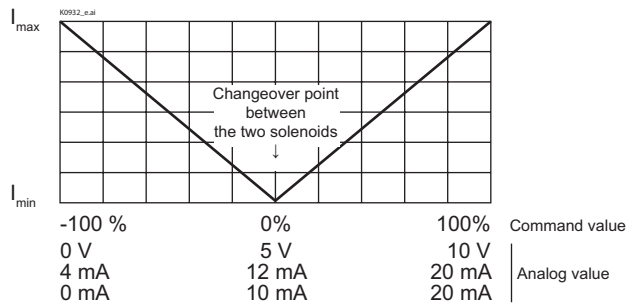

Operating mode command value bipolar (2-solenoids)

In dependence of a bipolar command value signal (voltage), according to the signal level, one of the two solenoids is driven. The changeover point between the two solenoids as standard is at 0V (e.g., -10...+10V correspond to -100...+100 % command value, -100...0 % command value correspond to I_{min}...I_{max} solenoid driver 2, 0...+100 % command value correspond to I_{min}...I_{max} solenoid driver 1).

Operating mode command value unipolar (2-solenoids with DigIn)

In dependence of a unipolar command signal (voltage, current, frequency or PWM) the solenoid is driven by the solenoid driver 1, if the selected digital input is «not activated», resp. the solenoid is driven by the solenoid driver 2, if the selected digital input is «activated» (e.g., 0...10V correspond to 0...100 % command value, 0...100 % command value correspond to I_{min} ... I_{max} solenoid driver 1 or 2).

Solenoid drivers

Four (in case of the basic version) or eight (in case of the enhanced version) pulse width modulated current outputs are available. A dither signal is superimposed on the output, whereby the dither frequency and the dither level are separately adjustable. For each output the minimum (I_{min}) and the maximum (I_{max}) current can be separately set. The solenoid outputs are also configurable as switching outputs. In doing so, a power reduction can be separately set for each output.

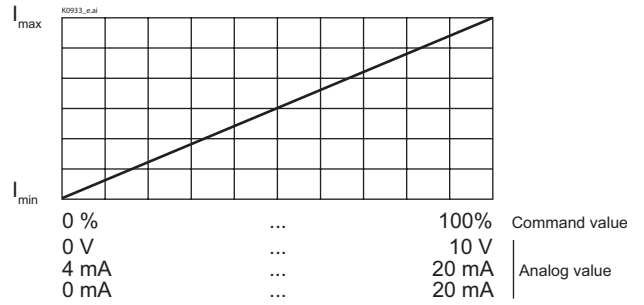
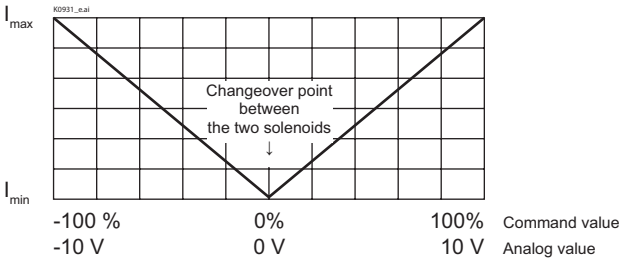

Changing over between the two solenoids by means of the selected digital input

CONNECTION EXAMPLE:

Amplifier module: MD2 Basic (all analogue inputs voltage):

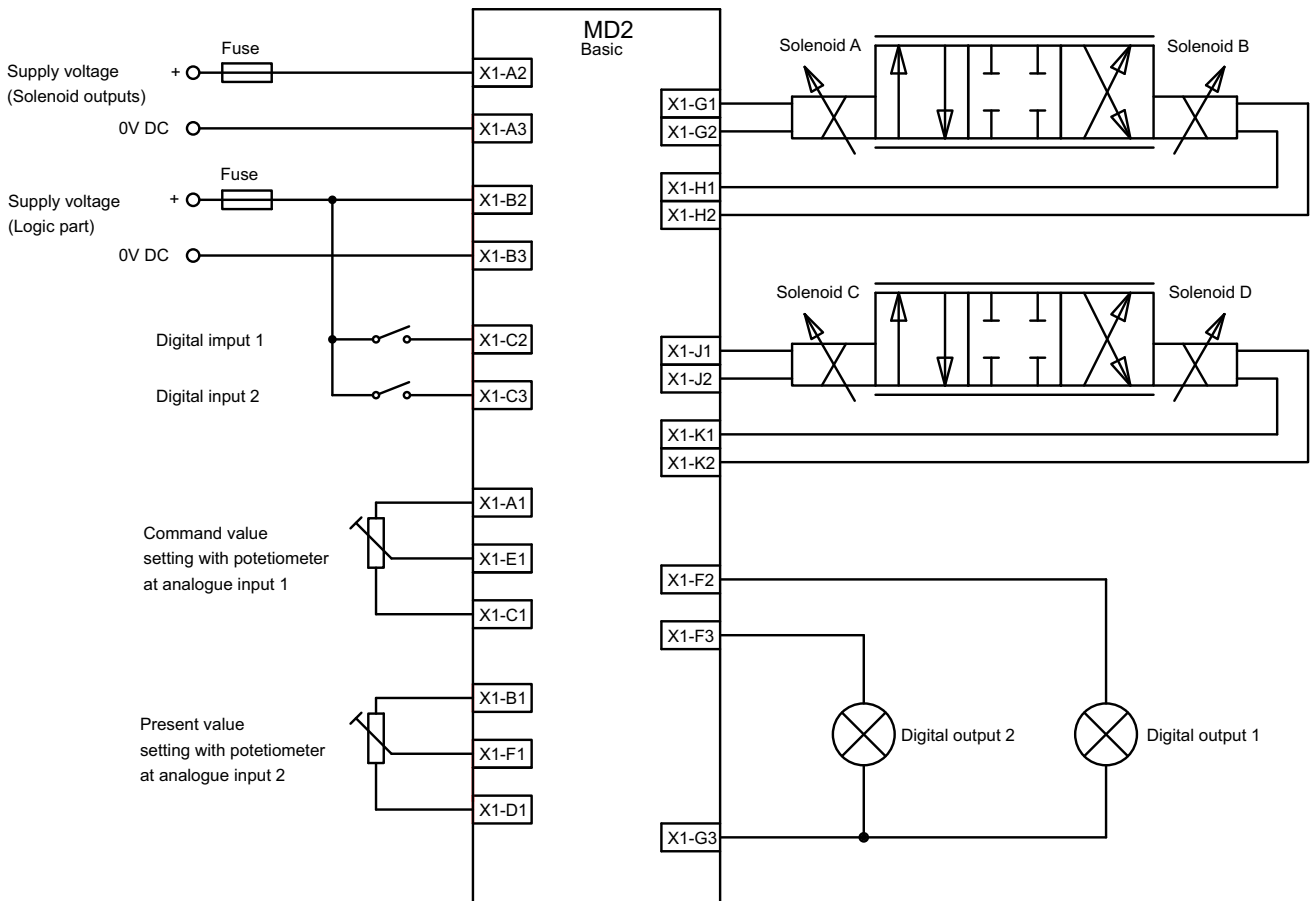

CONNECTION EXAMPLE:

Amplifier module: MD2 Enhanced (all analogue inputs voltage):

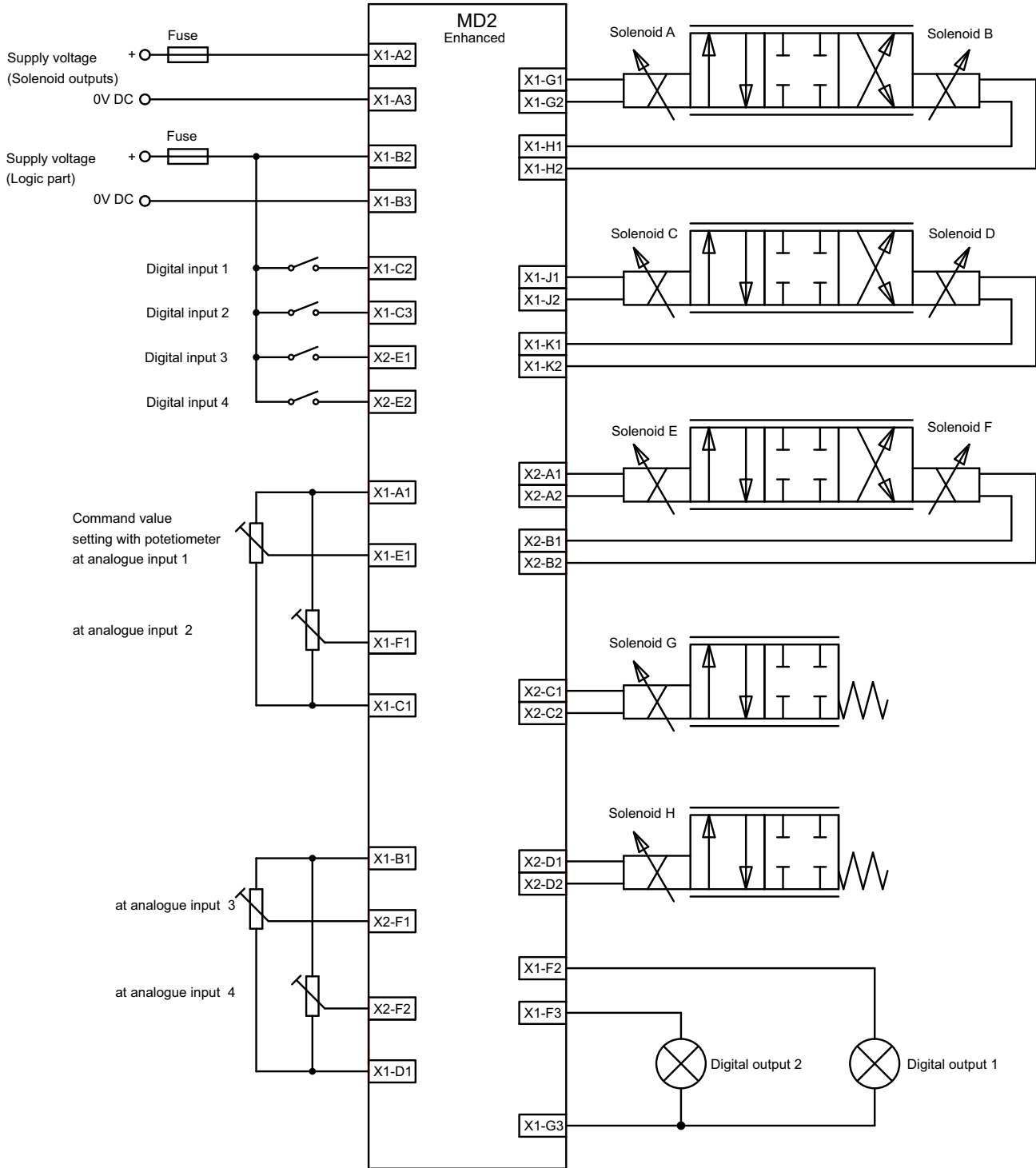

Description of the amplifier – and controller electronics «MD2»

DESIGN

The mobile electronics can be parameterised by means of the parameterisation software «PASO MD2» through the USB-interface. In addition, the parameterisation software makes a data analysis possible, with integrated graphic signal recording. The software «PASO MD2» is supported by Windows 2000, Windows XP and Windows Vista.

DESCRIPTION OF FUNCTION

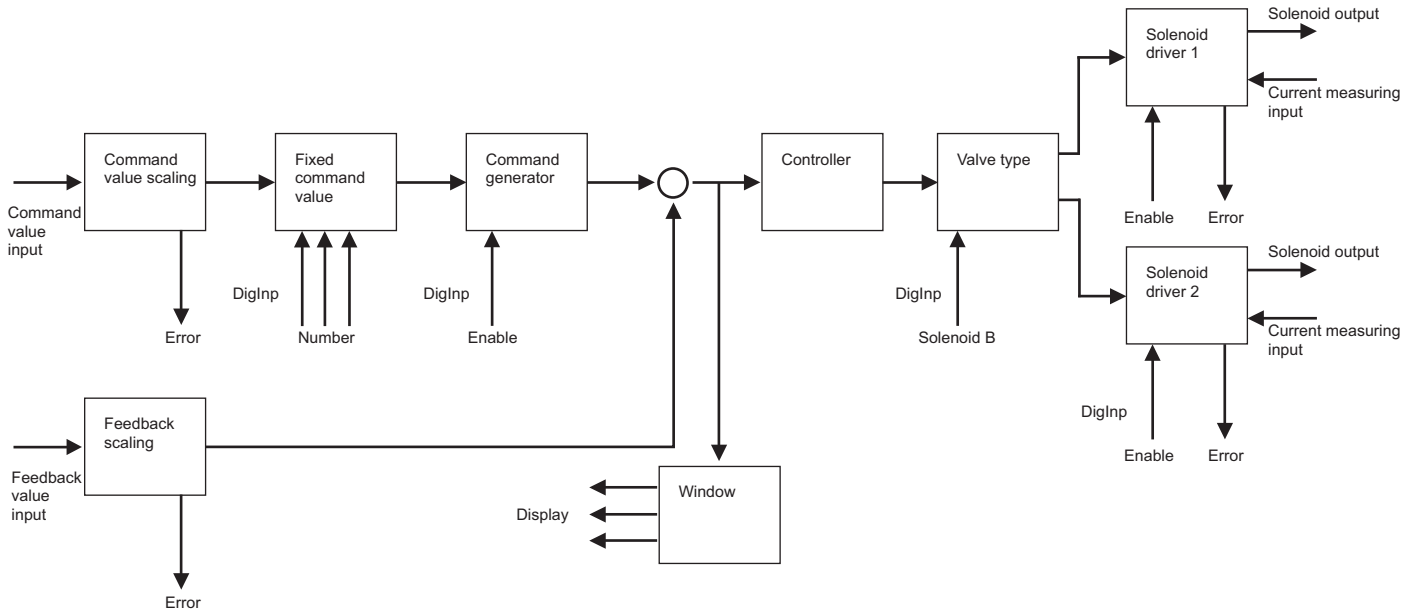

MD2 CONTROLLER

Command value scaling

The command value can be applied as a voltage -, current -, digital -, frequency - or PWM-signal. For each command value the input utilised can be selected. The scaling takes place through the parameters «Interface» and «Reference». Furthermore each command value can be monitored for cable break (excepting the voltage - and digital signal). In the version with CAN-connection, the command value can also be digitally transmitted.

Fixed command values

There are 7 fixed command values available, which can be selected through 3 digital inputs.

Command value generator

In the open-loop controller modes, two linear ramps separately settable for Up and Down are available per solenoid output. In the closed-loop controller modes, a positive and a negative travelling speed are available.

Feedback value scaling

The feedback value can be applied as a voltage -, current -, frequency - or PWM-signal. For each feedback signal the input utilised can be selected. The scaling takes place through the parameters «Interface» and «Reference». Furthermore each command value can be monitored for cable break (excepting the voltage signal). In the version with CAN-connection, the feedback value can be read-in by a sensor with CAN interface.

Windows

Available are a target -, contouring error - and solenoid-off window. In each window the threshold and the delay time can be adjusted.

Controller

Two (for the Basic version) or four (for the Enhanced version) controller circuits are available. The following controller modes can be selected:

Controller mode 3 «Pressure/volume flow valve control»

Driving of a pressure relief -, pressure control -, throttle - or flow control valve in the open control circuit (without feedback value return). The number of solenoids that are driven is dependent on the selected operating mode.

Controller mode 4 «Pressure/volume flow valve control (1-solenoid)»

Driving of a 1-solenoid pressure relief -, pressure control -, throttle - or flow control valve in the closed control circuit (with feedback value return). With it, only one solenoid can be driven (corresponds to the solenoid driver 1).

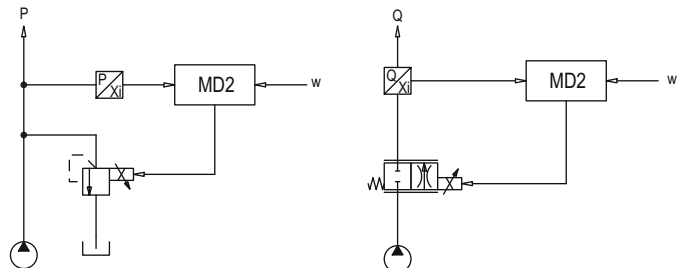

Controller mode -5 «Pressure control (2-solenoids)»

Driving of two 1-solenoid throttle valves in the closed control circuit (with feedback value return) as pressure reduction. In doing so, one of the throttle valves serves as the charge - and the other one as the discharge valve. The charge valve corresponds to the solenoid driver 1, the discharge valve to the solenoid driver 2 (graphics on the following page).

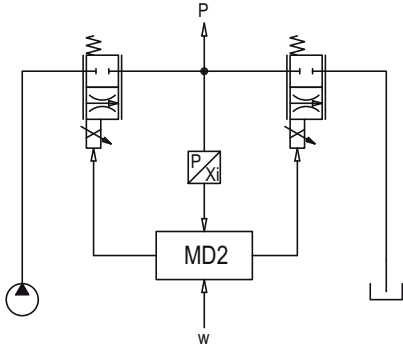

Controller mode 6 «Axis position controlled»

Driving of a directional control valve in the open control circuit (without feedback value return). The number of solenoids that are driven is dependent on the selected operating mode.

Controller mode 9 «Axis position controlled»

Driving of a 2-solenoid directional control valve in the closed control circuit (with feedback value return). With it, two solenoids can be driven.

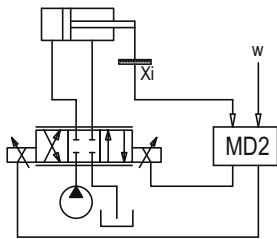

Controller mode 7 «Speed control (2-solenoids)»

Controlling of a 2-solenoid directional -, throttle - or flow control valve in the closed control circuit (with feedback value return). With it, two solenoids can be driven.

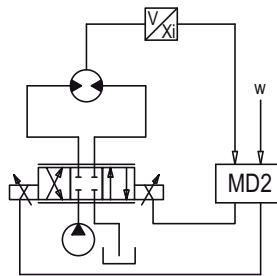

Controller mode -6 «2-Point controller (1-solenoid)»

Driving of a 1-solenoid valve with switching solenoid in the closed control circuit (with feedback value return). With it, only one solenoid can be driven (corresponds to the solenoid driver 1).

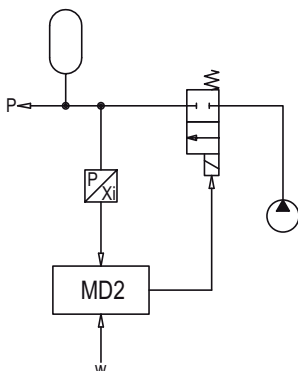

Controller mode -7 «2-Point controller (2-solenoids)»

Driving of a 2-solenoid valve with switching solenoid, resp. of two 1-solenoid valves with switching solenoid in the closed control circuit (with feedback value return). With it, two solenoids can be driven.

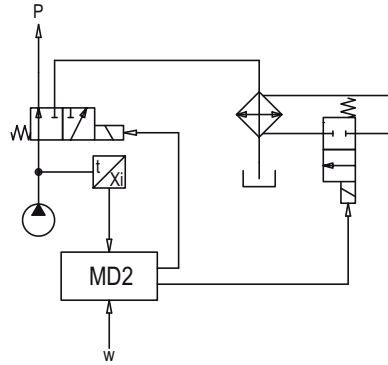

Controller mode -8 «3-Point controller (2-solenoids)»

Driving of a 2-solenoid valve with switching solenoid, resp., of two 1-solenoid valves with switching solenoid in the closed control circuit (with feedback value return). With it, two solenoids can be driven.

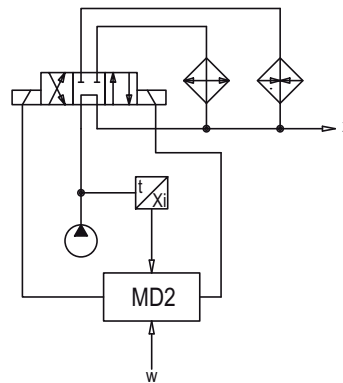

Valve type

Here the operating mode is set when in open-loop controller mode. In addition it can be selected, whether proportional - or switching solenoids are to be driven. A detailed description of the operating modes can be found in the section «Description of the MD2-amplifier electronics», page 6.

Solenoid drivers

Four (in the basic version) or eight (in the enhanced version) pulse width modulated current outputs are available. A dither signal is superimposed on the output, whereby the dither frequency and the dither level are separately adjustable. For each output the minimum (I_{min}) and the maximum (I_{max}) current can be separately set. The solenoid outputs are also configurable as switching outputs. In doing so, for each output a power reduction can be separately set.