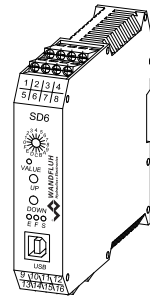

Digital amplifier module SD6

- for 1 or 2 proportional solenoids
- Interface: - analogue
- Profibus DP
- 2 analogue differential inputs
- max. 8 digital inputs
- 7 fixed command values
- Electronic card setting via PC
(optionally with manual operation on front panel)
- for snapping on to dome-rails

DESCRIPTION

Digital amplifier module for installation on dome-rails for driving proportional valves with one or two solenoids. The parameterisation takes place by means of menu-controlled parameterisation- and diagnostics software «PASO» from Wandfluh (USB-interface) or optionally with a manual control on the front panel. Separate ramps for up and down are integrated in the amplifier module as standard equipment. The electronics are equipped with optionally fixed settable command values or with Profibus-DP - interface.

FUNCTION

The amplifier module has one, resp., two Pulse-Width-Modulated current outputs with superimposed dither signal, whereby the dither frequency and the dither level can be adjusted separately. The preset value can be input as a voltage signal in the range of 0...10V, resp., ±10V (only 2-solenoid version), as a current signal 0...20mA resp. 4...20mA or applied through the field bus interface (Profibus DP). Up to 7 command values can be set and called-up (fixed command values). The amplifier module furthermore has one digital input each for the enabling and for the changeover from solenoid B, as well as one digital output each as «error identification» or «solenoid A active» (reversible) and «solenoid B active».

APPLICATION

As snap-on module the electronic card is mainly utilised in the industrial field. The module can be mounted on dome-rails. The connection with terminal screws enables commissioning without special tools in a short time. The amplifier module is particularly suitable for applications with additional functions such as ramps, preset values, etc. Customer-specific requirements can be implemented in a simple manner.

CONTENT

GENERAL SPECIFICATIONS 1

AMPLIFIER WITH ANALOGUE INTERFACE 3

AMPLIFIER WITH PROFIBUS INTERFACE 8

AMPLIFIER WITH ANALOGUE INTERFACE AND FIXED COMMAND VALUES 14

TYPE CODE

	S D6 <input type="checkbox"/> <input type="checkbox"/> <input type="checkbox"/> <input type="checkbox"/> <input type="checkbox"/> - A <input type="checkbox"/> # <input type="checkbox"/>
Module for electrical control cubicle	<input type="checkbox"/>
Digital	<input type="checkbox"/>
Parameters to be set with:	
• PASO and manual operation	<input type="checkbox"/> 2
• PASO without manual operation	<input type="checkbox"/> 3
Software configuration (function of card):	
• Standard amplifier	<input type="checkbox"/> 0
• Amplifier with operation mode 4	<input type="checkbox"/> 1 (only in case of PASO without manual operation)
• Amplifier with fixed command value	<input type="checkbox"/> 2
1-solenoid version	<input type="checkbox"/> 1
2-solenoid version	<input type="checkbox"/> 2
Supply voltage:	
24 VDC	<input type="checkbox"/> D2
12 VDC	<input type="checkbox"/> D3
Standard amplifier:	
• Preset value selectable voltage or current	<input type="checkbox"/> 0
Amplifier with operation mode 4:	
• Preset value: fixed, both voltage	<input type="checkbox"/> 1
• Preset value: fixed, both current	<input type="checkbox"/> 2
Hardware configuration:	
• 10-Bit resolution	<input type="checkbox"/>
Option field bus:	
• without field bus (with analogue input signal)	<input type="checkbox"/> A
• with Profibus DP	<input type="checkbox"/> B
	(Not in the case of SD6 with fixed command values) (Only in case of PASO without manual operation)
Design-Index (Subject to change)	<input type="checkbox"/>

GENERAL SPECIFICATIONS

Execution	Module for electrical control cubicle, housing made of plastic
Dimensions	
• Amplifier module analogue	105 x 114 x 22,5 mm (see dimensions)
• Amplifier module Profibus	105 x 114 x 45 mm (see dimensions)
• Amplifier module analogue with fixed command values	105x114x45 mm (see dimensions)
Installations	for 35 mm dome rail acc. to EN 60715
Weight	
• without Profibus DP	130 g
• with Profibus DP	220 g
Connections	Screw terminals, max. cable cross-sections 2,5 mm ²
Working temperature	-20...+70 °C
	In operation mode 4, the total solenoid current of simultaneously powered solenoids depends on the ambient temperature.
	Further information can be found in the operating instructions.

Amplifier with analogue interface

ELECTRICAL SPECIFICATIONS

Protection class	IP30 acc. to EN 60 529	<i>Solenoid current:</i>	
Supply voltage	24 VDC or 12 VDC	• Minimal current I_{min}	Adjustable 0...950 mA Factory-preset 150 mA
Voltage range:		• Maximal current I_{max}	Adjustable $I_{min} \dots 1,8A$ (with 24 VDC) $I_{min} \dots 2,3A$ (with 12 VDC) Factory-preset 700 mA
• 24 VDC	21...30 V	• Accumulated current limitation	In operation mode 4, the total solenoid current of simultaneously powered solenoids depends on the ambient temperature. Further information can be found in the operating instructions.
• 12 VDC	10,5...15 V	Dither	Frequency adjustable 20...500 Hz Factory-preset 100 Hz Amplitude adjustable 0...400 mA Factory-preset 100 mA
Ripple on supply vol.	<10%	Temperature drift	<1% at $\Delta T = 40^\circ C$
Fuse	slow	Digital inputs	Switching threshold high 6...30 VDC Switching threshold low 0...1 VDC Signal active at 6...30 VDC (active high) On request: Signal active at 0...1 VDC (active low)
Current consumption:		Digital outputs	Low-Side-Switch: $U_{max} = 40$ VDC $I_{max} = -700$ mA
• No-load current	ca. 40 mA	Ramps adjustable	0...500 s
• Maximum current consumption	no-load current + 1,8 A per solenoid (with 24 VDC) no-load current + 2,3 A per solenoid (with 12 VDC)	Serial interface	USB (receptacle type B) to set parameters with «PASO»
Command value signal:	Selectable with software Diff. inputs not galvanically separated, for earth potential differences up to 1,5 V 4...+20 mA/0...+20 mA 0...+10 V (1- or 2-solenoid version) -10...+10 V (only 2-solenoid version)	EMV	
Input resistance	Voltage input >18 k Ω Load for current input = 250 Ω	Immunity	EN 61 000-6-2
Stabilised output voltage	10 VDC (with version 24 VDC) 8 VDC (with version 12 VDC) max. load 30 mA	Emission	EN 61 000-6-4

BLOCK DIAGRAM

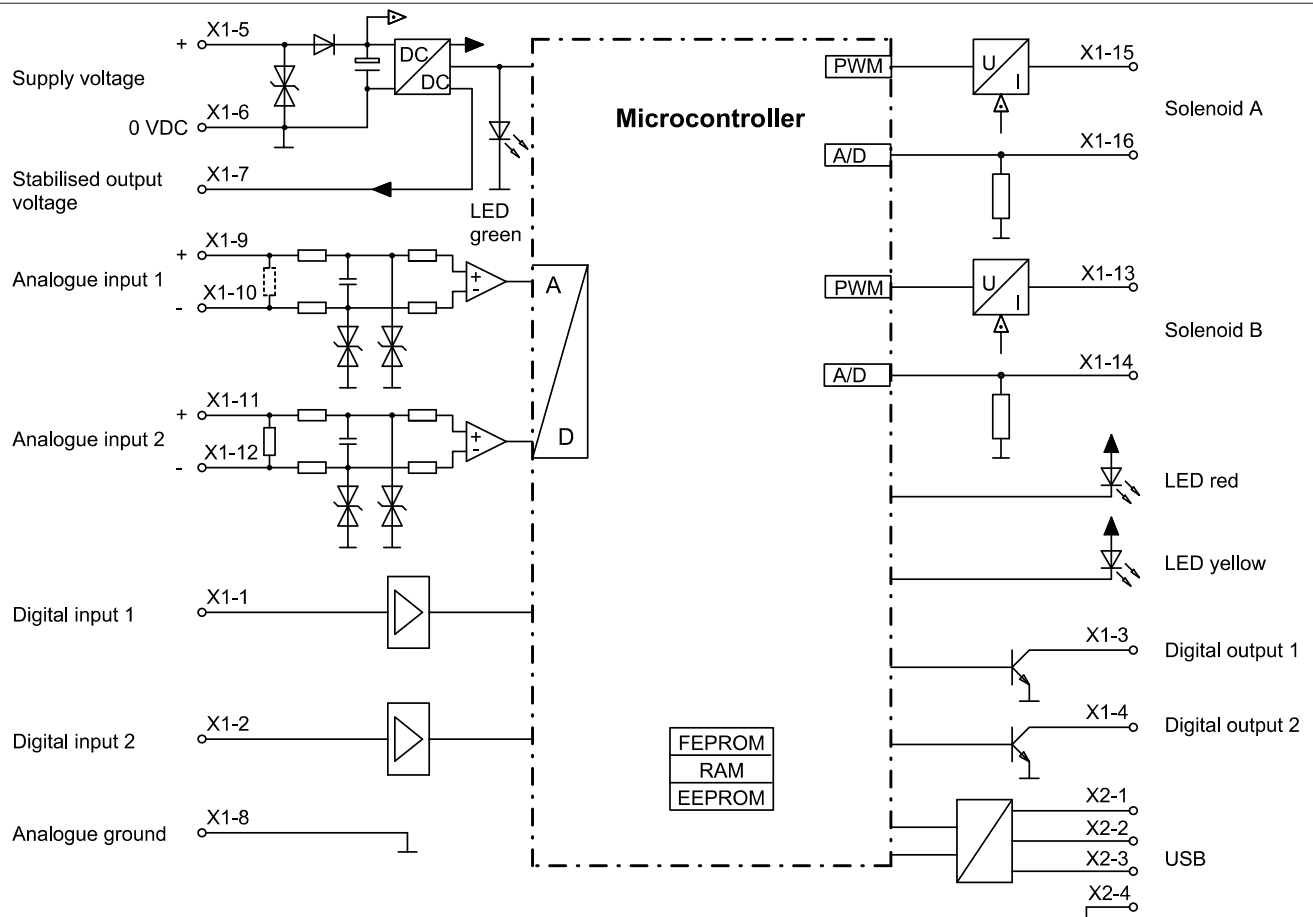

DIMENSIONS

Type: SD63

Type: SD62

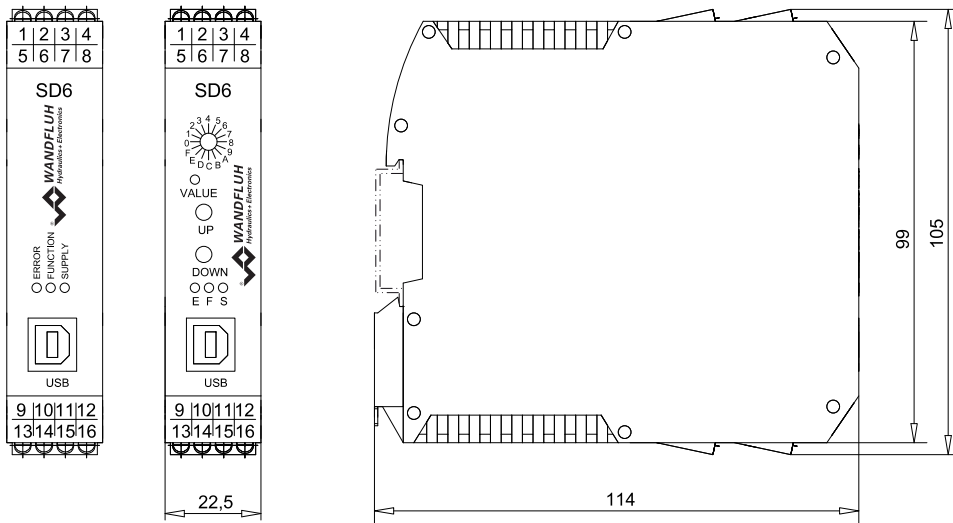
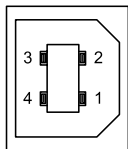
CONNECTOR WIRING DIAGRAM / PIN ASSIGNMENT
USB-interface, USB Type B X2

- 1 = VBUS
- 2 = D-
- 3 = D+
- 4 = GND

REMARK!

The parameterisation cable is not part of the scope of supply (commercially available USB-cable, plug type A to plug type B)

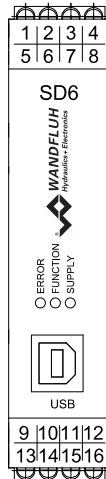
PIN-assignment X1

- 1 = Digital input 1
- 2 = Digital input 2
- 3 = Digital output 1
- 4 = Digital output 2
- 5 = Supply Analogue input+
- 6 = Supply voltage 0 VDC
- 7 = Stabilised output voltage
- 8 = Analogue ground
- 9 = Analogue input 1+
- 10 = Analogue input 1-
- 11 = Analogue input 2+
- 12 = Analogue input 2-
- 13 = Output solenoid B+
- 14 = Output solenoid B-
- 15 = Output solenoid A+
- 16 = Output solenoid A-

Configuration Analogue input

Type description	Analogue input 1	Analogue input 2
SD6.0.D.0-AA	Voltage	Current
SD6312D.1-AA	Voltage	Voltage
SD6312D.2-AA	Current	Current

START-UP

Information regarding installation and commissioning are contained in the information leaflet supplied with the amplifier module and in the operating instructions.

Additional information can be found on our website:
 «www.wandfluh.com»

Free-of-charge download:

- «PASO-DSV/SD6» Parameterisation software
- Operating instructions (*pdf)

ADDITIONAL INFORMATION

Wandfluh electronics general Accessories	Wandfluh documentation register	1.13
Proportional directional valves	register	1.10
Proportional pressure valves	register	2.3
Proportional flow control valves	register	2.6

DESCRIPTION of «SD6»-electronics with analog interface

Design

The amplifier module can be parameterised by means of the parameterisation software «PASO-DSV/SD6» through the USB-interface. In addition, the parameterisation software makes a data analysis possible. The software «PASO-DSV/SD6» is supported by Windows 2000 and Windows XP.

Description of Function
Hardware-Configuration with Analogue Signal

The amplifier module SD6 serves for driving proportional valves and has one (in the case of the 1-solenoid version) or two (in the case of the 2-solenoid version) **Pulse-Width-Modulated** current outputs with superimposed dither signal, whereby the dither frequency and the dither level can be set separately. In the case of the 1-solenoid version, the preset value can be input in a range of 0...10 V (voltage input) or 0...20 mA, resp., 4...20 mA (current input). In case of the 2-solenoid version, the preset value can be input in the range of 0...10 V, resp., 0...±10 V (voltage input) or 0...20 mA, resp., 4...20 mA (current input). The amplifier module furthermore has two digital inputs for the enabling and the changeover from solenoid A to solenoid B, as well as two digital outputs for «Error detection» or «Solenoid A active» (reversible) and «Solenoid B active». The parameterisation takes place through the parameterisation software «PASO-DSV/SD6» and optionally through a manual parameterisation interface. Changed parameters are stored in a non-volatile memory, so that they are available again after a renewed switching-on of the control system.

Operating mode 1: Command value unipolar (1-sol.)

This operating mode is only selectable in case of the 1-solenoid version. In dependence of a unipolar analogue input (voltage or current), the solenoid is driven. (0...10 V, 0...20 mA, 4...20 mA respectively correspond to 0...100% preset value signal)/(0...100% preset value signal correspond to I_{min} ... I_{max} solenoid).

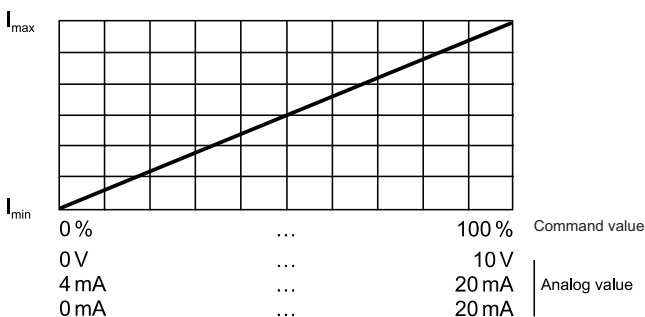

Optionally the amplifier module is equipped with a manual control, which enables the setting of the most important parameters by means of rotary selector switch and push-buttons and therefore makes a commissioning of the amplifier module possible without a PC.

Operating mode 2: Command value unipolar (2-sol.)

This operating mode is only selectable in case of the 2-solenoid version. In dependence of a unipolar analogue input (voltage or current), depending on the signal level solenoid A or solenoid 2 is driven. The changeover threshold between the two solenoids as standard setting is in the middle of the values range of the analogue signal. (0...10 V, 0...20 mA, 4...20 mA respectively correspond to -100%...+100% of the command value signal)/(-100...0% preset value signal correspond to I_{max} ... I_{min} solenoid B and 0...100% preset value signal correspond to I_{min} ... I_{max} solenoid A).

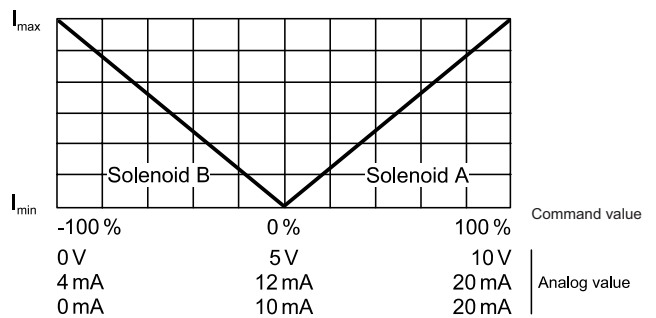

Operating mode 3: Command value bipolar (2-sol.)

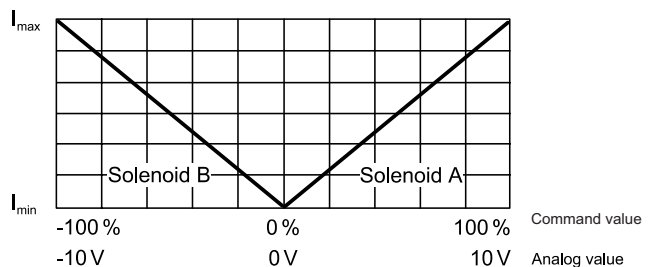
This operating mode is only selectable in case of the 2-solenoid version. In dependence of a bipolar analogue input (voltage), depending on the signal level solenoid A or solenoid B is driven. The changeover threshold between the two solenoids as standard setting is at 0 V. (-10...+10 V correspond to -100...+100% preset value signal)/(-100...0% command value signal correspond to I_{max} ... I_{min} solenoid B and 0...100% command value signal correspond to I_{min} ... I_{max} solenoid A).

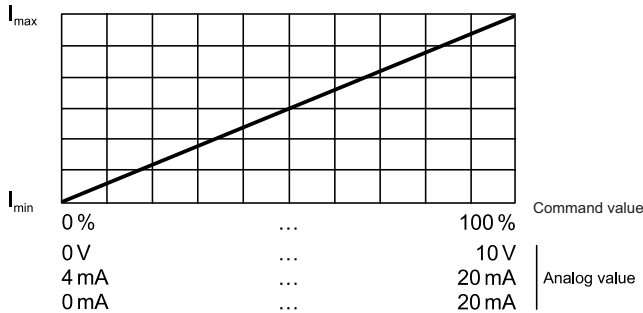

Operating mode 4: Command value unipolar (2-sol. single)
 (2-solenoid version)

In this operating mode every solenoid output can be driven by a pre-set value of its own (refer to connection example «Operating mode 4»). This operating mode is only selectable in case of the 2-solenoid version with the option «Amplifier with operating mode 4». Depending on the analogue input 1 (voltage or current, refer to type code), solenoid A is driven, and depending on the analogue input 2 (voltage or current, refer to type code), solenoid B is driven. (0...10 V, 0...20 mA, 4...20 mA respectively correspond to 0...100 % command value signal) / (0...100 % preset value signal correspond to 1 ... I_{max} solenoid).



Analogue input 1: Solenoid A

Analogue input 2: Solenoid B

Operating mode 5: Command value unipolar (2-sol. with DigInp2)
 (2-solenoid version)

This operating mode is only selectable in case of the 2-solenoid version. Depending on a unipolar analogue input (voltage or current), solenoid A is driven, when the digital input 2 «is not activated», resp., solenoid B, when the digital input 2 is «activated». (0...10 V, 0...20 mA, 4...20 mA respectively correspond to 0...100 % command value signal) / (0...100 % command value signal correspond to I_{min} ... I_{max} solenoid).

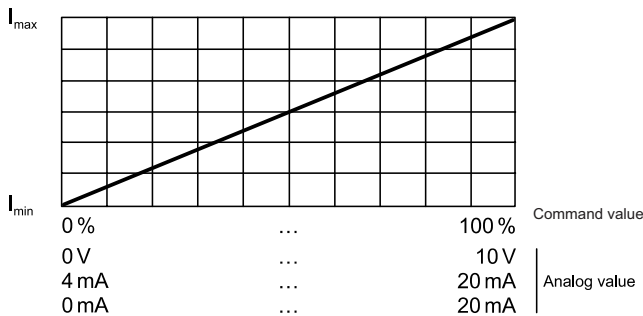

Solenoid A, when the digital input 2 is on «not activated»

Solenoid B, when the digital input 2 is on «activated»

Command value inputs

The analogue signal present is digitalised in the 10-bit A/D-converter.

Attention:

When selecting the range 4...20 mA, the resolution is <10-bit! All pre-set value inputs are executed as differential inputs. Differential inputs are utilised, when the potential of the mass of the external command value transmitter does not coincide with the potential of the mass on the «SD6»-electronics card. If the differential input is to be utilised like an analogue input against mass, then the - (minus) connection of the differential input has to be connected to mass.

Cable-break protection at command value inputs

The current analogue inputs can be monitored for cable-break. If a cable-break is detected, the solenoid output is blocked (disabled) and the output «Error» is activated. For the monitoring to be effective, the following conditions have to be fulfilled:

- The input signal has to be a current signal 4...20 mA.
- The cable-break monitoring has to be activated.

Attention:

Approx. 100 ms pass until a cable break is identified. During this time period, the connected hydraulic system can make unintended movements or change unintended forces.

Analogue input voltage

Input voltage range 0...±10 V

If in case of the version 12 VDC, the stabilised voltage (0...8 V) is utilised, then in the PASO-«SD6» the scaling [%/V] has to be correspondingly adapted.

Analogue input current

Input current range 0...20 mA/4...20 mA

Digital input 1 «Enable control»

Enables the «SD6»-electronics in general. Without this enabling, no solenoid current is output. The digital input 1 as standard setting is high-active (refer to electrical characteristic values).

Digital input 2 «Solenoid B»

In the operating mode 5 «Preset value unipolar (2-sol. with DigInp2)», the solenoid B is active, when the digital input 2 is «active». When the digital input 2 is «inactive», then solenoid A is active.

Digital output 1 «Error» or «Solenoid A active»

The function of the digital output 1 with the parameterisation software PASO-DSV/SD6 can be set to «Error» or «Solenoid A active». In the case of «Error» this output becomes active, when an error is detected. Once detected, an error is indicated for as long as the «SD6»-electronics is blocked (disabled) and then enabled again through the digital input «Enable control». In the case of «Solenoid A active», this output becomes active, when the solenoid A is driven. The digital output is a low-side switch (refer to electrical characteristic values).

Digital output 2 «Solenoid B active»

The digital output 2 only has significance in case of the 2-solenoid version. This output becomes active, when the solenoid B is driven. The digital output is a low-side switch (refer to electrical characteristic values).

Ramps

Per solenoid two linear ramps for up and down are separately settable.

CONNECTION EXAMPLE (digital amplifier module with analogue interface)

Operating mode 2, 3 and 5

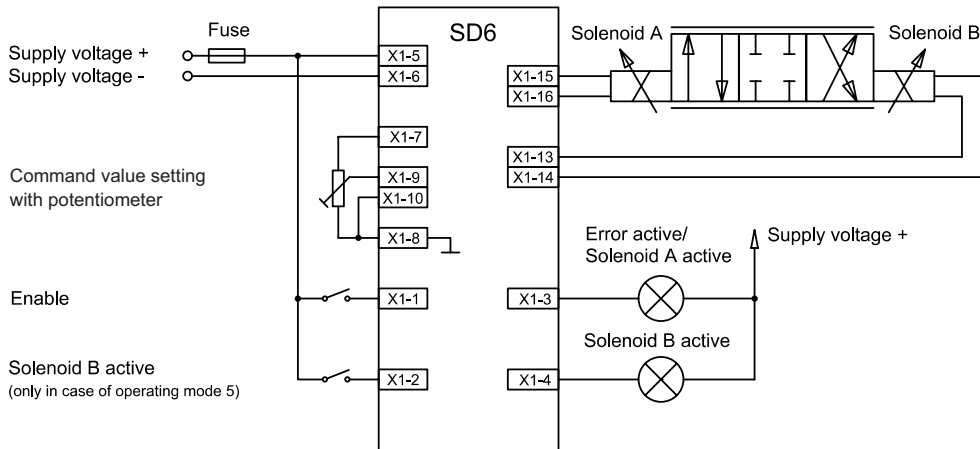

Operating mode 4 (Command value inputs: Fixed, both voltage)

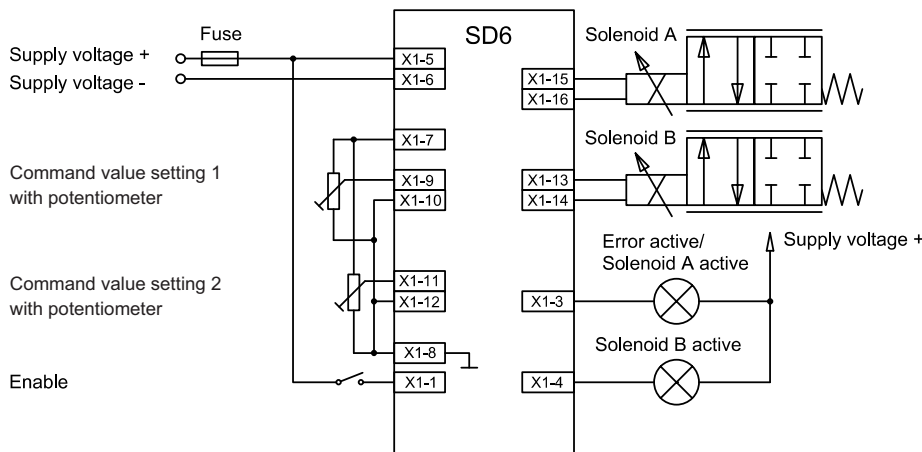

Amplifier with Profibus DP-interface

ELECTRICAL SPECIFICATIONS

Protection class	IP 30 acc. to EN 60 529	Profibus interface	D-Sub-Plug-in coupling DSUB, 9-poles, female on front plate, differential signal transmission
Device receptacle	DSUB, 9-poles	Bus topology	Line
Profibus (female)	Plug (male)	Potential separation:	Profibus to «SD6»-electronics 500 VDC
Mating connector	DSUB, 9-poles	Solenoid current:	
Supply voltage	24 VDC or 12 VDC	• Minimal current I_{min}	Adjustable 0...950 mA Factory-preset 150 mA
Voltage range:		• Maximal current I_{max}	Adjustable $I_{min}...1,8A$ (with 24 VDC) $I_{min}...2,3A$ (with 12 VDC) Factory-preset 700 mA
• 24 VDC	21...30 V	• Accumulated current limitation	In operation mode 4, the total solenoid current of simultaneously powered solenoids depends on the ambient temperature. Further information can be found in the operating instructions.
• 12 VDC	10,5...15 V	Dither	Frequency adjustable 20...500 Hz Factory-preset 100 Hz Amplitude adjustable 0...400 mA Factory-preset 100 mA
Ripple on supply vol.	<10 %	Temperature drift	<1 % at $\Delta T = 40^\circ C$
Fuse	slow	Digital inputs	Switching threshold high 6...30 VDC Switching threshold low 0...1 VDC Signal active at 6...30 VDC (active high) On request: Signal active at 0...1 VDC (active low)
Current consumption:		Digital outputs	Low-Side-Switch: $U_{max} = 40$ VDC $I_{max} = -700$ mA
• No-load current	approx. 50 mA	Ramps adjustable	0...500 s
• Maximum current consumption	no-load current + 1,8 A per solenoid (with 24 VDC) no-load current + 2,3 A per solenoid (with 12 VDC)	Serial interface	USB (receptacle type B) to set parameters with «PASO»
Command value signal:	Selectable with software Diff. inputs not galvanically separated, for earth potential differences up to 1,5 V 4...+20 mA/0...+20 mA 0...+10 V (1- or 2-solenoid version) -10...+10 V (only 2-solenoid version, not with analogue input 2)	EMV	
Input resistance	Voltage input >18 k Ω Load for current input = 250 Ω	Immunity	EN 61 000-6-2
Stabilised output voltage	10 VDC (with version 24 VDC) 8 VDC (with version 12 VDC) max. load 30 mA	Emission	EN 61 000-6-4

BLOCK DIAGRAM

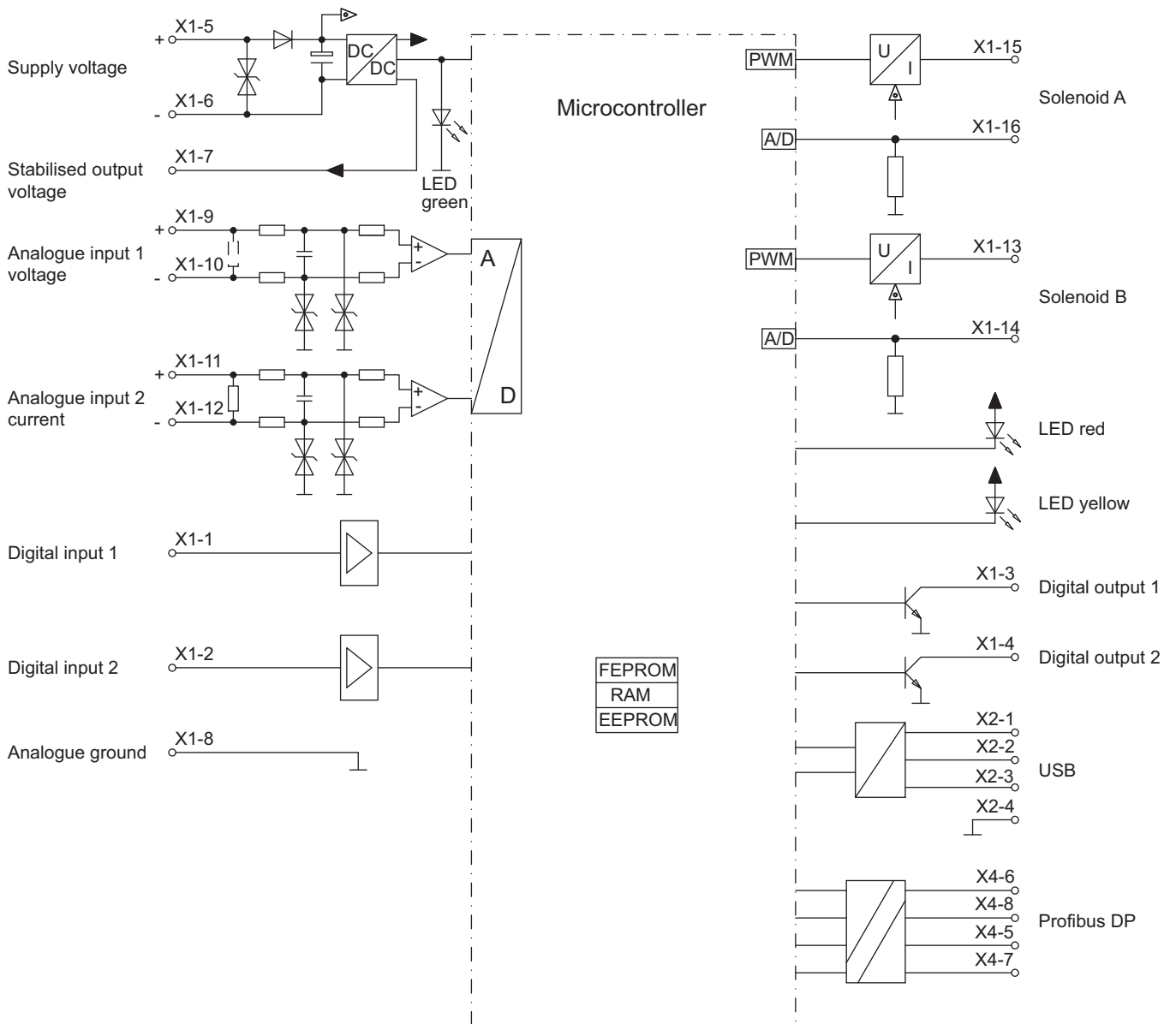

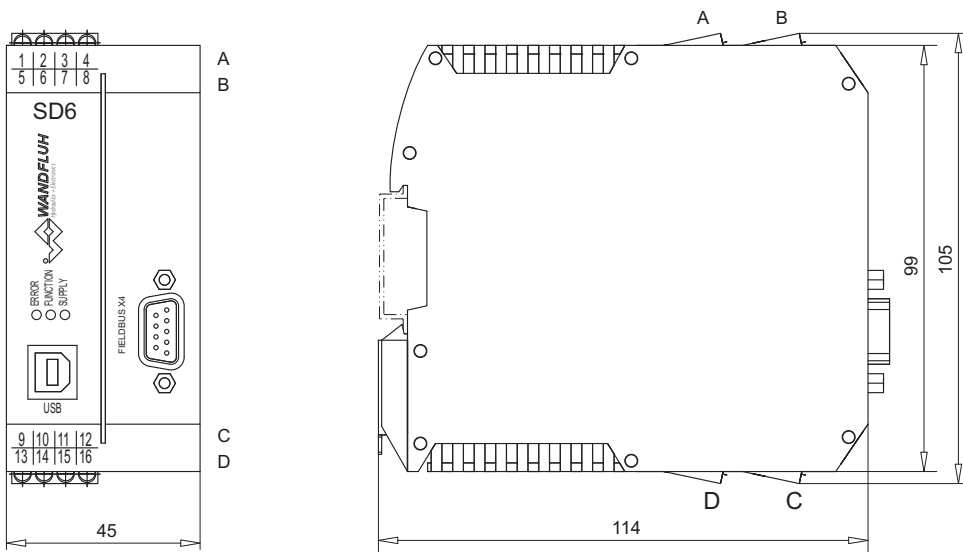
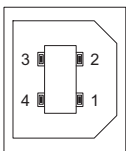
DIMENSIONS

CONNECTOR WIRING DIAGRAM / PIN ASSIGNMENT
USB-interface, USB Type B X2

- 1 = VBUS
- 2 = D -
- 3 = D +
- 4 = GND

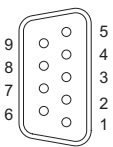

REMARK!

The parameterisation cable is not part of the scope of supply (commercially available USB-cable, plug type A to plug type B)

Device receptacle Profibus (female) X4

PROFIBUS

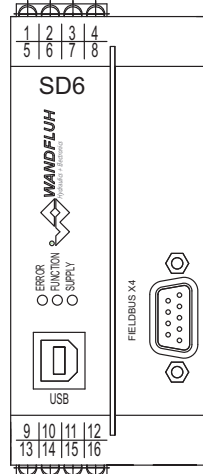
- 1 = Reserved
- 2 = Reserved
- 3 = RxD/TxD-P
- 4 = Reserved
- 5 = DGND
- 6 = VP
- 7 = Reserved
- 8 = RxD/TxD-N
- 9 = Reserved

The mating connector (plug male, DSUB, 9-poles) is not included in the delivery.

PIN-assignment X1

- 1 = Digital input 1
- 2 = Digital input 2
- 3 = Digital output 1
- 4 = Digital output 2
- 5 = Supply Analogue input +
- 6 = Supply voltage 0 VDC
- 7 = Stabilised output voltage
- 8 = Analogue ground
- 9 = Analogue input 1 +
- 10 = Analogue input 1 -
- 11 = Analogue input 2 +
- 12 = Analogue input 2 -
- 13 = Output solenoid B +
- 14 = Output solenoid B -
- 15 = Output solenoid A +
- 16 = Output solenoid A -

Configuration Analogue input

Type description	Analogue input 1	Analogue input 2
SD630 . D . 0-AB	Voltage	Current
SD6312D . 1-AB	Voltage	Voltage (0...10 V only)
SD6312D . 2-AB	Current	Current

START-UP

Information regarding installation and commissioning are contained in the information leaflet supplied with the amplifier module and in the operating instructions.

Additional information can be found on our website:
 «www.wandfluh.com»

Free-of-charge download:

- «PASO-DSV/SD6» Parameterisation software
- Operating instructions (*pdf)
- GSD File «WAGOB8E.gsd»

ADDITIONAL INFORMATION

Wandfluh electronics general Accessories	Wandfluh documentation register	1.13
Proportional directional valves	register	1.10
Proportional pressure valves	register	2.3
Proportional flow control valves	register	2.6

DESCRIPTION of «SD6»-Electronics with Profibus DP-interface

Design

The amplifier module can be parameterised by means of the parameterisation software «PASO-DSV/SD6» through the USB-interface. In addition, the parameterisation software makes a data analysis possible. The software «PASO-DSV/SD6» is supported by Windows 2000 and Windows XP.

Description of Function
Hardware-Configuration with Profibus DP-interface

The amplifier module SD6 serves for driving proportional valves and has one (in the case of the 1-solenoid version) or two (in the case of the 2-solenoid version) **Pulse-Width-Modulated** current outputs with superimposed dither signal, whereby the dither frequency and the dither level can be set separately. In the case of the 1-solenoid version, the command value can be input in a range of 0...10 V (voltage input), 0...20 mA, resp., 4...20 mA (current input) or applied through the field bus DP. In case of the 2-solenoid version, the command value can be input in the range of 0...10 V, resp., 0...±10 V (voltage input) or 0...20 mA, resp., 4...20 mA (current input) or applied through the field bus DP. The amplifier module furthermore has two digital inputs for the enabling and the changeover from solenoid A to solenoid B, as well as two digital outputs for «Error detection» or «Solenoid A active» (reversible) and «Solenoid B active». The parameterisation takes place through the parameterisation software «PASO-DSV/SD6» and optionally through a manual parameterisation interface. Changed parameters are stored in a non-volatile memory, so that they are available again after a renewed switching-on of the control system.

Operating mode 1: Command value unipolar (1-sol.)

This operating mode is only selectable in case of the 1-solenoid version. In dependence of a unipolar analogue input (voltage or current), the solenoid is driven. (0...10 V, 0...20 mA, 4...20 mA respectively correspond to 0...100% preset value signal)/(0...100% preset value signal correspond to I_{min} ... I_{max} solenoid).

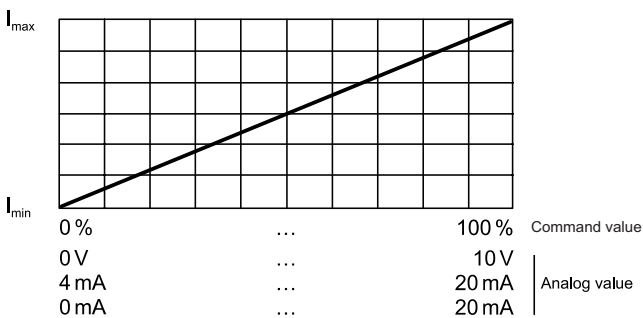

Optionally the amplifier module is equipped with a manual control, which enables the setting of the most important parameters by means of rotary selector switch and push-buttons and therefore makes a commissioning of the amplifier module possible without a PC.

Operating mode 2: Command value unipolar (2-sol.)

This operating mode is only selectable in case of the 2-solenoid version. In dependence of a unipolar analogue input (voltage or current), depending on the signal level solenoid A or solenoid 2 is driven. The changeover threshold between the two solenoids as standard setting is in the middle of the values range of the analogue signal. (0...10 V, 0...20 mA, 4...20 mA respectively correspond to -100%...+100% of the preset value signal)/(-100...0% preset value signal correspond to I_{max} ... I_{min} solenoid B and 0...100% preset value signal correspond to I_{min} ... I_{max} solenoid A).

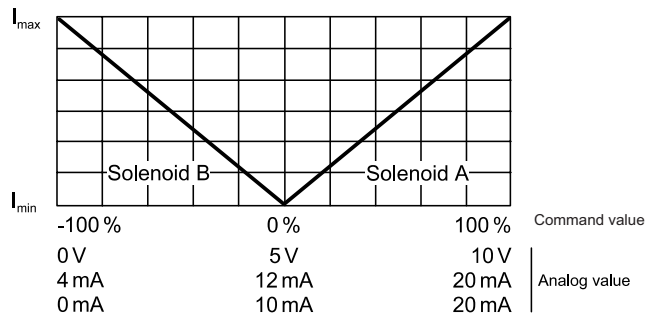

Operating mode 3: Command value bipolar (2-sol.)

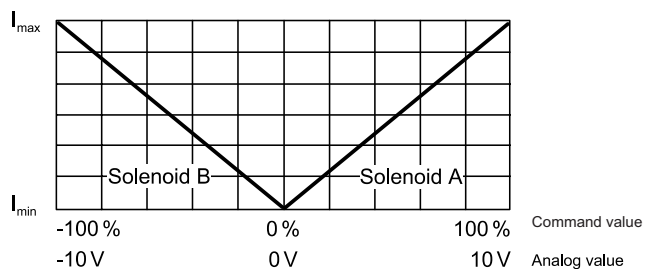
This operating mode is only selectable in case of the 2-solenoid version. In dependence of a bipolar analogue input (voltage), depending on the signal level solenoid A or solenoid B is driven. The changeover threshold between the two solenoids as standard setting is at 0 V. (-10...+10 V correspond to -100...+100% preset value signal)/(-100...0% preset value signal correspond to I_{max} ... I_{min} solenoid B and 0...100% preset value signal correspond to I_{min} ... I_{max} solenoid A).

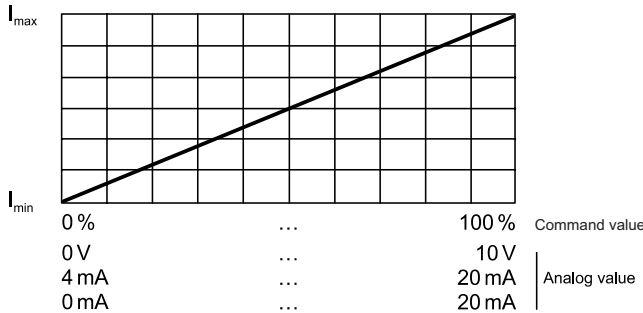

Operating mode 4: Command value unipolar (2-sol. single)
 (2-solenoid version)

In this operating mode every solenoid output can be driven by a command value of its own (refer to connection example «Operating mode 4»). This operating mode is only selectable in case of the 2-solenoid version with the option «Amplifier with operating mode 4». Depending on the analogue input 1 (voltage or current, refer to type code), solenoid A is driven, and depending on the analogue input 2 (voltage or current, refer to type code), solenoid B is driven. (0...10 V, 0...20 mA, 4...20 mA respectively correspond to 0...100% preset value signal) / (0...100% preset value signal correspond to I_{min} ... I_{max} solenoid).



Analogue input 1: Solenoid A

Analogue input 2: Solenoid B

Operating mode 5: Command value unipolar (2-sol. with DigInp2)
 (2-solenoid version)

This operating mode is only selectable in case of the 2-solenoid version. Depending on a unipolar analogue input (voltage or current), solenoid A is driven, when the digital input 2 «is not activated», resp., solenoid B, when the digital input 2 is «activated». (0...10 V, 0...20 mA, 4...20 mA respectively correspond to 0...100% preset value signal) / (0...100% command value signal correspond to I_{min} ... I_{max} solenoid).

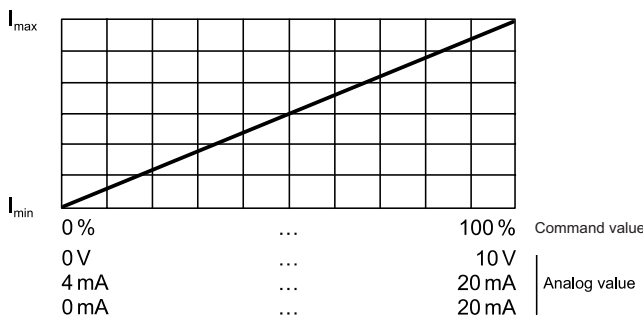

Solenoid A, when the digital input 2 is on «not activated»

Solenoid B, when the digital input 2 is on «activated»

Command value inputs

The analogue signal present is digitalised in the 10-bit A/D-converter.

Attention:

When selecting the range 4...20 mA, the resolution is <10-bit! All preset value inputs are executed as differential inputs. Differential inputs are utilised, when the potential of the mass of the external preset value transmitter does not coincide with the potential of the mass on the «SD6»-electronics card. If the differential input is to be utilised like an analogue input against mass, then the - (minus) connection of the differential input has to be connected to mass.

Cable-break protection at preset value inputs

The current analogue inputs can be monitored for cable-break. If a cable-break is detected, the solenoid output is blocked (disabled) and the output «Error» is activated. For the monitoring to be effective, the following conditions have to be fulfilled:

- The input signal has to be a current signal 4...20 mA.
- The cable-break monitoring has to be activated.

Attention:

Approx. 100 ms pass until a cable break is identified. During this time period, the connected hydraulic system can make unintended movements or change unintended forces.

Analogue input voltage

Input voltage range 0...±10 V, analogue input 2: 0...10 V.

If in case of the version 12 VDC, the stabilised voltage (0...8 V) is utilised, then in the PASO-«SD6» the scaling [%/V] has to be correspondingly adapted.

Analogue input current

Input current range 0...20 mA/4...20 mA

Digital input 1 «Enable control»

Enables the «SD6»-electronics in general. Without this enabling, no solenoid current is output. The digital input 1 as standard setting is high-active (refer to electrical characteristic values).

Digital input 2 «Solenoid B»

In the operating mode 5 «Preset value unipolar (2-sol. with DigInp2)», the solenoid B is active, when the digital input 2 is «active». When the digital input 2 is «inactive», then solenoid A is active.

The digital inputs 1–2 can only be utilised with local device control (db.local=1).

Digital output 1 «Error» or «Solenoid A active»

The function of the digital output 1 with the parameterisation software PASO-DSV/SD6 can be set to «Error» or «Solenoid A active». In the case of «Error» this output becomes active, when an error is detected. Once detected, an error is indicated for as long as the «SD6»-electronics is blocked (disabled) and then enabled again through the digital input «Enable control». In the case of «Solenoid A active», this output becomes active, when the solenoid A is driven. The digital output is a low-side switch (refer to electrical characteristic values).

Digital output 2 «Solenoid B active»

The digital output 2 only has significance in case of the 2-solenoid version. This output becomes active, when the solenoid B is driven. The digital output is a low-side switch (refer to electrical characteristic values).

Ramps

Per solenoid two linear ramps for up and down are separately settable.

CONNECTION EXAMPLE (Digital amplifier module with Profibus DP-interface)

Operating mode 2, 3 and 5

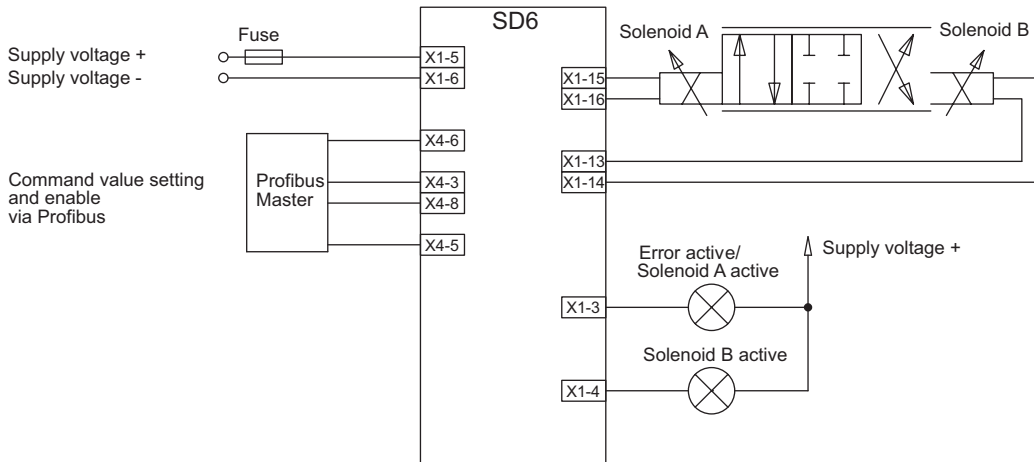

Operating mode 4 (Command value inputs: Fixed, both voltage)

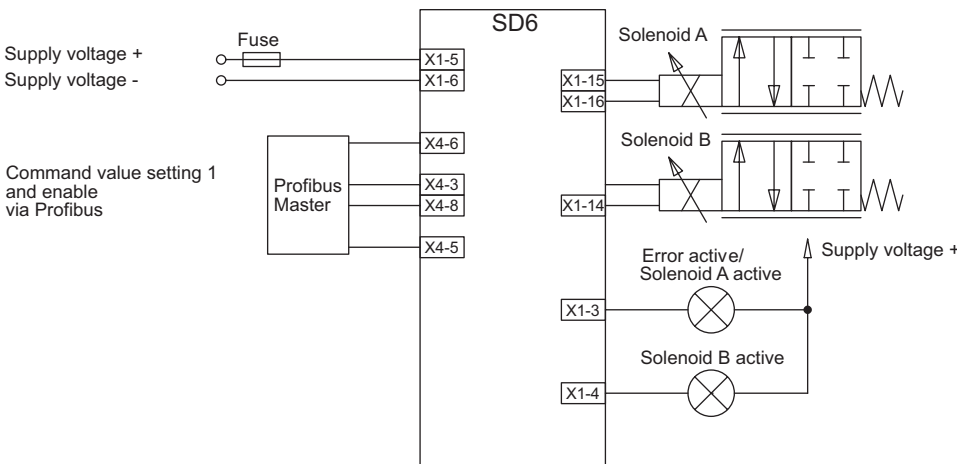

Amplifier with analogue interface and fixed command values

ELECTRICAL SPECIFICATIONS

Protection class	IP 30 acc. to EN 60 529	<i>Solenoid current:</i>	
Supply voltage	24 VDC or 12 VDC	• Minimal current I_{min}	Adjustable 0...950 mA Factory-preset 150 mA
<i>Voltage range:</i>		• Maximal current I_{max}	Adjustable I_{min} ...1,8A (with 24 VDC) I_{min} ...2,3A (with 12 VDC) Factory-preset 700 mA
• 24 VDC	21...30 V		Frequency adjustable 20...500 Hz
• 12 VDC	10,5...15 V		Factory-preset 100 Hz
Ripple on supply vol.	<10 %	Dither	Amplitude adjustable 0...400 mA Factory-preset 100 mA
Fuse	slow		<1 % at $\Delta T = 40^\circ C$
<i>Current consumption:</i>		Temperature drift	Switching threshold high 6...30 VDC
• No-load current	ca. 40 mA	Digital inputs	Switching threshold low 0...1 VDC
• Maximum current consumption	no-load current + 1,8 A per solenoid (with 24 VDC) no-load current + 2,3 A per solenoid (with 12 VDC)		Signal active at 6...30 VDC (active high)
Preset value signal:	Selectable with software Diff. inputs not galvanically separated, for earth potential differences up to 1,5 V		On request: (digital input 1 + 2)
	4...+20 mA/0...+20 mA	Digital outputs	Signal active at 0...1 VDC (active low)
	0...+10 V (1- or 2-solenoid version)		Low-Side-Switch:
	-10...+10 V (only 2-solenoid version)		$U_{max} = 40$ VDC
Input resistance	Voltage input >18 k Ω		$I_{max} = -700$ mA
	Load for current input = 250 Ω	Ramps adjustable	0...500 s
Stabilised output voltage	10 VDC (with version 24 VDC) 8 VDC (with version 12 VDC) max. load 30 mA	Serial interface	USB (receptacle type B) to set parameters with «PASO»
		EMV	
		Immunity	EN 61 000-6-2
		Emission	EN 61 000-6-4

BLOCK DIAGRAM

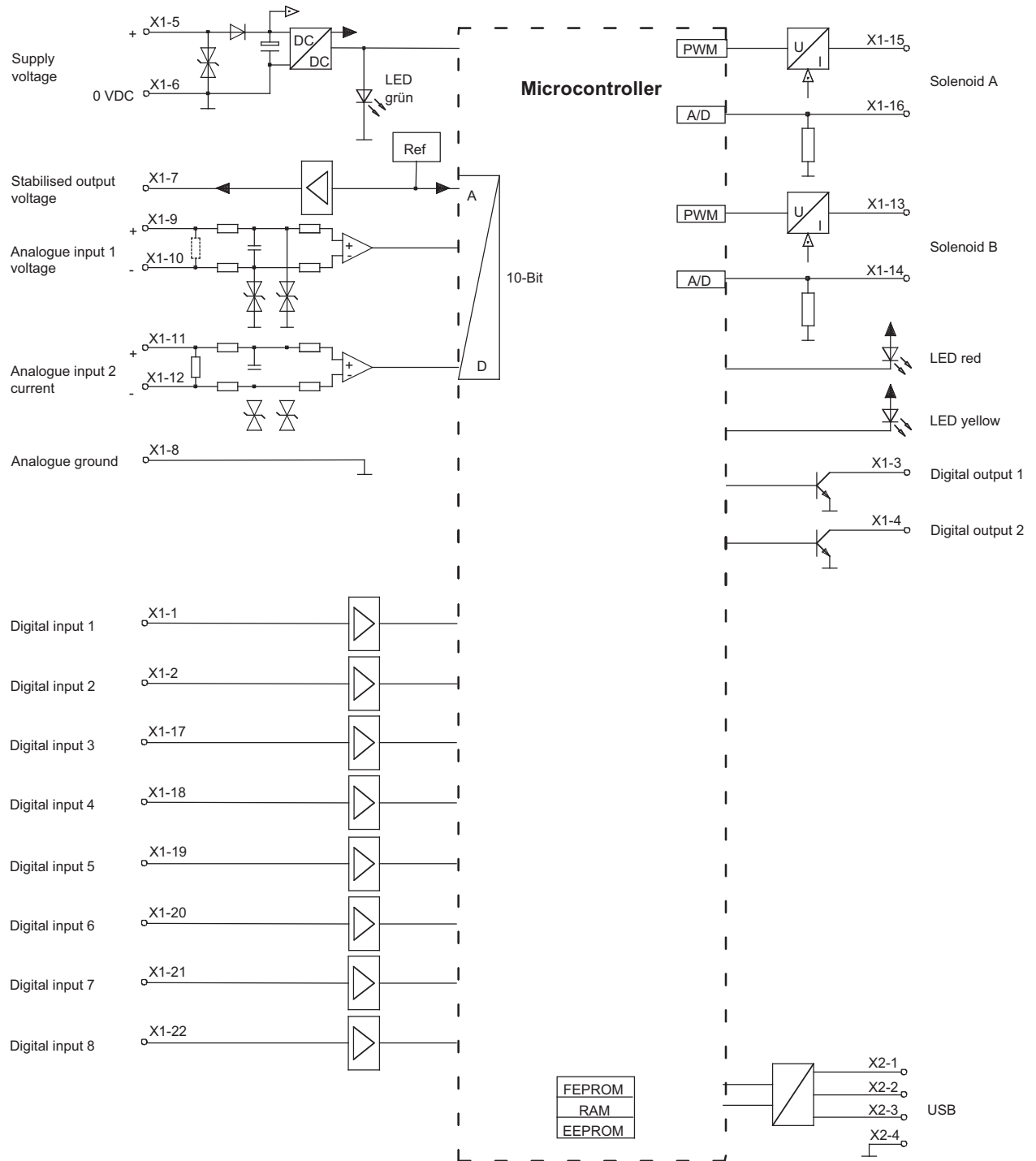

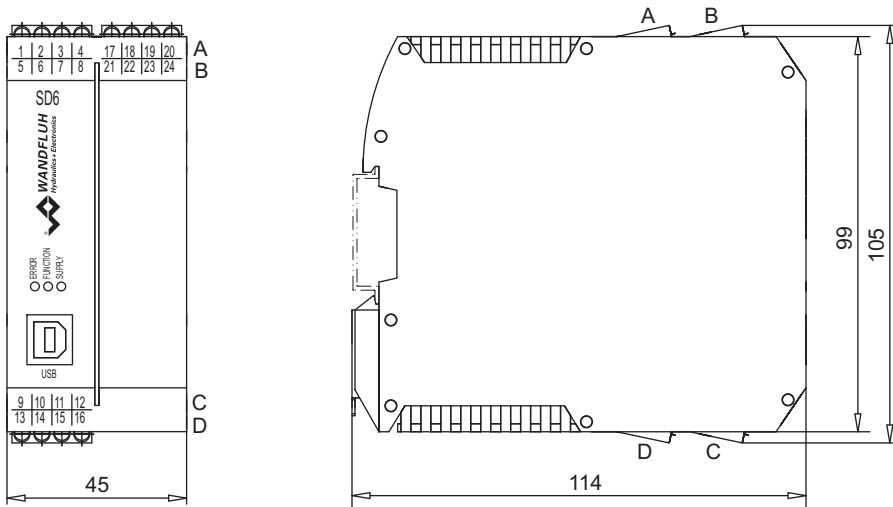
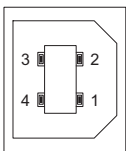
DIMENSIONS

CONNECTOR WIRING DIAGRAM / PIN ASSIGNMENT
USB-interface, USB Type B X2

- 1 = VBUS
- 2 = D -
- 3 = D +
- 4 = GND

REMARK!

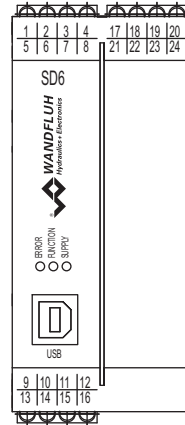
The parameterisation cable is not part of the scope of supply (commercially available USB-cable, plug type A to plug type B)

PIN-assignment X1

- 1 = Digital input 1
- 2 = Digital input 2
- 3 = Digital output 1
- 4 = Digital output 2
- 5 = Supply Analogue input +
- 6 = Supply voltage 0 VDC
- 7 = Stabilised output voltage
- 8 = Analogue ground
- 9 = Analogue input 1 +
- 10 = Analogue input 1 -
- 11 = Analogue input 2 +
- 12 = Analogue input 2 -
- 13 = Output solenoid B +
- 14 = Output solenoid B -
- 15 = Output solenoid A +
- 16 = Output solenoid A -
- 17 = Digital input 3
- 18 = Digital input 4
- 19 = Digital input 5
- 20 = Digital input 6
- 21 = Digital input 7
- 22 = Digital input 8
- 23 = reserved
- 24 = reserved

START-UP

Information regarding installation and commissioning are contained in the information leaflet supplied with the amplifier module and in the operating instructions.

Additional information can be found on our website:
 «www.wandfluh.com»

Free-of-charge download:

- «PASO-DSV/SD6» Parameterisation software
- Operating instructions (*pdf)

ADDITIONAL INFORMATION

	Wandfluh documentation
Wandfluh electronics general	register 1.13
Accessories	register 1.13
Proportional directional valves	register 1.10
Proportional pressure valves	register 2.3
Proportional flow control valves	register 2.6

Configuration Analogue input

Type description	Analogue input 1	Analogue input 2
SD632.D. 0-AA	voltage	current

DESCRIPTION of «SD6»-electronics with analog interface and fixed command values

Design

The amplifier module can be parameterised by means of the parameterisation software «PASO-DSV/SD6» through the USB-interface. In addition, the parameterisation software makes a data analysis possible. The software «PASO-DSV/SD6» is supported by Windows 2000 and Windows XP.

Description of Function
Hardware-Configuration with Analogue Signal

The amplifier module SD6 serves for driving proportional valves and has one (in the case of the 1-solenoid version) or two (in the case of the 2-solenoid version) **Pulse-Width-Modulated** current outputs with superimposed dither signal, whereby the dither frequency and the dither level can be set separately. In the case of the 1-solenoid version, the preset value can be input in a range of 0...10 V (voltage input) or 0...20 mA, resp., 4...20 mA (current input). In case of the 2-solenoid version, the preset value can be input in the range of 0...10 V, resp., 0...±10 V (voltage input) or 0...20 mA, resp., 4...20 mA (current input). The command value can also be internally set instead of the external analogue signal and called-up through three digital inputs. With this, in total seven „fixed command values“ are available, which can be selected by means of binary coding. The amplifier module furthermore has five digital inputs for the enabling, the changeover from solenoid A to solenoid B and a blocking of the ramping function as well as two digital outputs for «Error detection» or «Solenoid A active» (reversible) and «Solenoid B active». The parameterisation takes place through the parameterisation software «PASO-DSV/SD6». Changed parameters are stored in a non-volatile memory, so that they are available again after a renewed switching-on of the control system.

Operating mode 1: Command value unipolar (1-sol.)

This operating mode is only selectable in case of the 1-solenoid version. In dependence of a unipolar analogue input (voltage or current), the solenoid is driven. (0...10 V, 0...20 mA, 4...20 mA respectively correspond to 0...100% preset value signal)/(0...100% preset value signal correspond to I_{min} ... I_{max} solenoid).

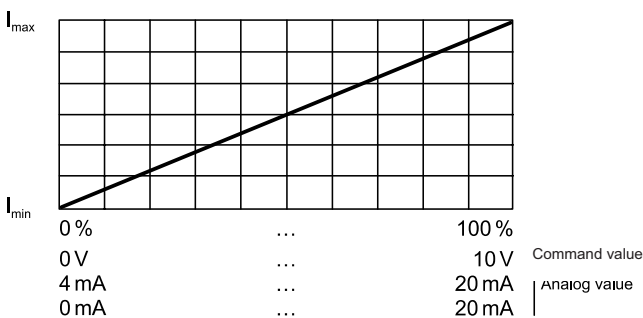
Operating mode 2: Command value unipolar (2-sol.)

This operating mode is only selectable in case of the 2-solenoid version. In dependence of a unipolar analogue input (voltage or current), depending on the signal level solenoid A or solenoid 2 is driven. The changeover threshold between the two solenoids as standard setting is in the middle of the values range of the analogue signal. (0...10 V, 0...20 mA, 4...20 mA respectively correspond to -100%...+100% of the preset value signal)/(-100...0% preset value signal correspond to I_{max} ... I_{min} solenoid B and 0...100% preset value signal correspond to I_{min} ... I_{max} solenoid A).

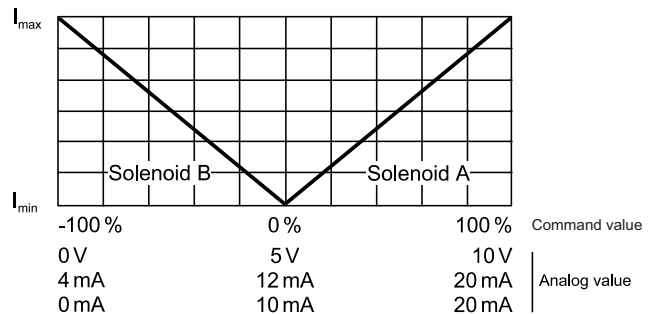

Operating mode 3: Command value bipolar (2-sol.)

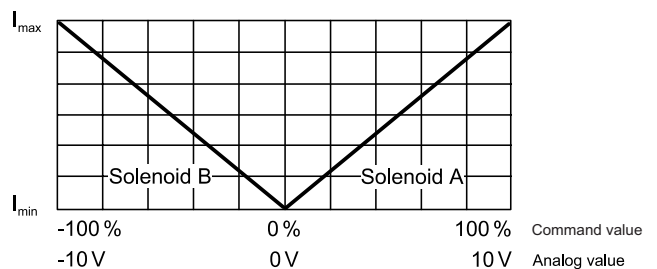
This operating mode is only selectable in case of the 2-solenoid version. In dependence of a bipolar analogue input (voltage), depending on the signal level solenoid A or solenoid B is driven. The changeover threshold between the two solenoids as standard setting is at 0 V. (-10...+10 V correspond to -100...+100% command value signal)/(-100...0% command value signal correspond to I_{max} ... I_{min} solenoid B and 0...100% command value signal correspond to I_{min} ... I_{max} solenoid A).

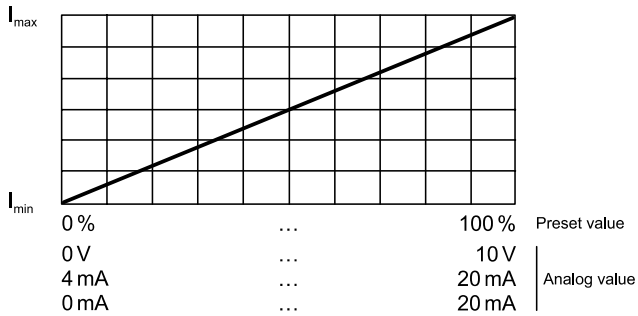

Operating mode 5: Command value unipolar (2-sol. with DigInp4)
 (2-solenoid version)

This operating mode is only selectable in case of the 2-solenoid version. Depending on a unipolar analogue input (voltage or current), solenoid A is driven, when the digital input 4 «is not activated», resp., solenoid B, when the digital input 4 is «activated». (0...10 V, 0...20 mA, 4...20 mA respectively correspond to 0...100% preset value signal) / (0...100% preset value signal correspond to I_{min} ... I_{max} solenoid).



Solenoid A, when the digital input 4 is on «not activated»

Solenoid B, when the digital input 4 is on «activated»

Command value inputs

The analogue signal present is digitalised in the 10-bit A/D-converter.

Attention:

When selecting the range 4...20 mA, the resolution is <10-bit! All preset value inputs are executed as differential inputs. Differential inputs are utilised, when the potential of the mass of the external preset value transmitter does not coincide with the potential of the mass on the «SD6»-electronics card. If the differential input is to be utilised like an analogue input against mass, then the - (minus) connection of the differential input has to be connected to mass.

Cable-break protection at preset value inputs

The current analogue inputs can be monitored for cable-break. If a cable-break is detected, the solenoid output is blocked (disabled) and the output «Error» is activated. For the monitoring to be effective, the following conditions have to be fulfilled:

- The input signal has to be a current signal 4...20 mA.
- The cable-break monitoring has to be activated.

Attention:

Approx. 100 ms pass until a cable break is identified. During this time period, the connected hydraulic system can make unintended movements or change unintended forces.

Analogue input voltage

Input voltage range 0...±10 V

If in case of the version 12 VDC, the stabilised voltage (0...8 V) is utilised, then in the PASO-«SD6» the scaling [%/V] has to be correspondingly adapted.

Analogue input current

Input current range 0...20 mA/4...20 mA

Digital input 1 (disable solenoid A)

If the input is set, solenoid output A is disabled.

Digital input 2 (disable solenoid B)

If the input is set, solenoid output B is disabled.

Digital input 3 (enable control)

If the input is set, the solenoid outputs are enabled, if not, they are disabled.

Digital input 4 (solenoid B active)

If a directional valve is commanded by a voltage preset value 0... +10 V or a current preset value, digital input 4 must be set to activate solenoid output B (only in case of operating mode 5).

Digital input 5 (ramp off)

The ramp can be temporarily switched off by setting this input.

Digital inputs 6 to 8 (fixed preset values)

Seven fixed preset values, selectable in binary form, are available. When a fixed preset value is selected via digital inputs 6 to 8, the external preset value is ineffective.

Digital output 1 „Error“ or „Solenoid A active“

The function of the digital output 1 with the parameterisation software PASO-DSV/SD6 can be set to „Error“ of „Solenoid A active“. In the case of „Error“ this output becomes active, when an error is indicated for as long as the „SD6“-electronics is blocked (disabled) and then enabled again through the digital input „Enable control“. In the case of „Solenoid A active“, this output becomes active, when the solenoid A is driven. The digital output is a low-side switch (refer to electrical characteristic values).

Digital output 2 „Solenoid B active“

The digital output 2 only has significance in case of the 2-solenoid version. This output becomes active, when the solenoid B is driven. The digital output is a low-side switch (refer to electrical characteristic values).

Ramps

Per solenoid two linear ramps for up and down are separately settable.

CONNECTION EXAMPLE (digital amplifier module with analogue interface)

Operating mode 2, 3 and 5

